



TW 242 PE B4.3

Two Post Lift
Lifting Capacity: 4200 KG

twinbusch.de



INSTALLATION, OPERATION AND MAINTENANCE MANUAL



Read this entire manual carefully before installation or operation of the lift. Follow the instructions strictly.

Twin Busch GmbH | Amperestraße 1 | D-64625 Bensheim
Tel.: +49 (0) 6251-70585-0 | Fax: +49 (0) 6251-70585-29 | info@twinbusch.de



INDEX

1. Important safety instructions.....	3~4
1.1 Important notices	
1.2 Qualified personnel	
1.3 Danger notices	
1.4 Training	
1.5 Warning signs	
2. Overview of the lift.....	5
2.1 General descriptions	
2.2 Technical data	
2.3 Construction of the lift	
3. Installation instructions.....	6~14
3.1 Preparations before installation	
3.2 Precautions for installation	
3.3 Installation	
3.4 Items to be checked after installation	
4. Operation instructions.....	15~16
4.1 Precautions	
4.2 Flow chart for operation	
4.3 Operating instructions	
5. Trouble shooting.....	17
6. Maintenance.....	18
7. Annex.....	19~34
Annex1, Packing list of the whole lift	
Annex2, Overall diagram	
Annex3, Floor plan	
Annex4, Wiring diagram	
Annex5, Hydraulic working system	
Annex6, Separated drawings for the lift	
Annex7, Spare parts list	

IMPORTANT SAFETY INSTRUCTIONS

1.1 Important notices

We will offer one-year's quality warranty for the whole machine, during which any quality problem will be properly solved to the user's satisfaction. However, we will not take any responsibility for whatever bad consequence resulted from improper installation and operation, overload running or unqualified ground condition.

This 2-posts lift is specially designed for lifting motor vehicles that weighs within its outmost lifting capacity. Users are not allowed to use it for any other purposes. Otherwise, we, as well as our sales agency, will not bear any responsibility for accidents or damages of the lift. Make sure to pay careful attention to the label of the lifting capacity attached on the lift and never try to lift cars with its weight beyond.

Read this manual carefully before operating the machine so as to avoid economic loss or personnel casualty incurred by wrong operation.

Without our professional advice, users are not permitted to make any modification to the control unit or whatever mechanical unit.

1.2 Qualified personnel

1.2.1 Only these qualified staff, who have been properly trained, can operate the lift.

1.2.2 Electrical connection must be done by a competent electrician.

1.2.3 People who are not concerned are not allowed in the lifting area.

1.3 Danger notices

1.3.1 Do not install the lift on any asphalt surface.

1.3.2 Read and understand all safety warnings before operating the lift.

1.3.3 The lift, if is not specially designed upon customer's request, is not fit for outdoor use.

1.3.4 Keep hands and feet away from any moving parts. Keep feet clear of the lift when lowering.

1.3.5 Only these qualified people, who have been properly trained, can operate the lift.

1.3.6 Do not wear unfit clothes such as large clothes with flounces, tires, etc, which could be caught by moving parts of the lift.

1.3.7 To prevent evitable incidents, surrounding areas of the lift must be tidy and with nothing unconcerned.

1.3.8 The lift is simply designed to lift the entire body of vehicles, with its maximum weight within the lifting capacity.

1.3.9 Always insure the safety latches are engaged before any attempt to work near or under the vehicle.

1.3.10 Make sure to place the lifting pads to the positions as suggested by vehicle makers and when gradually lift the vehicle to the desired height, operators should be certain that the vehicle will not slant, roll-over or slide in lifting process.

1.3.11 Check at any time the parts of the lift to ensure the agility of moving parts and the performance of synchronization. Ensure regular maintenance and if anything abnormal occurs, stop using the lift immediately and contact our dealers for help.

1.3.12 Lower the lift to its lowest position and do remember to cut off the power source when service finishes.

1.3.13 Do not modify any parts of the lift without manufacturer's advice.

1.3.14 If the lift is going to be left unused for a long time, users are required to:

- a. Disconnect the power source;
- b. Empty the oil tank;
- c. Lubricate the moving parts with hydraulic oil.

1.4 Training

















Only these qualified people, who have been properly trained, can operate the lift. We are quite willing to provide professional training for the users when necessary.

Attention: For environment protection, please dispose the disused oil in a proper way.



1.5 Warning signs

All safety warning signs attached on the machine are for the purpose of drawing the user's attention to safety operation. The labels must be kept clean and need to be replaced when they are worn-out or have dropped. Read the explanations of the labels carefully and try to memorize them.

 <p>ATTENTION!</p> <p>Please read the instruction manual and safety warnings before using!</p>	 <p>ATTENTION!</p> <p>Use of the lift by qualified personnel only!</p>	 <p>ATTENTION!</p> <p>Use only the vehicle manufactures recommended lifting points!</p>	 <p>ATTENTION!</p> <p>Check vehicle for security shortly after lifting!</p>
 <p>ATTENTION!</p> <p>Repairs and maintenancem only by qualified personnel, do not tamper with lift safety devices!</p>	 <p>ATTENTION!</p> <p>Only quali ed personnel are allowed within the lift working area!</p>	 <p>ATTENTION!</p> <p>Never exceed the recomended lifting capacity!</p>	 <p>ATTENTION!</p> <p>Attention when removing heavy vehicle parts!</p>
 <p>ATTENTION!</p> <p>Always keep escape routes free!</p>	 <p>ATTENTION!</p> <p>No persons under the lift (when lifting or lowering)!</p>	 <p>ATTENTION!</p> <p>Never try to lift using only one side of the lift!</p>	 <p>ATTENTION!</p> <p>Protect the lift against damp, especially the electrical connections!</p>
 <p>ATTENTION!</p> <p>Always take care of your feet when lowering!</p>	 <p>ATTENTION!</p> <p>Never climb on the lift!</p>	 <p>ATTENTION!</p> <p>Avoid excessive shaking of the vehicle!</p>	 <p>ATTENTION! Danger of shock!</p>

OVERVIEW OF THE LIFT

2.1 General descriptions

This two- post lift is composed of posts, carriages, lifting arms, cylinders and motor unit, etc.

The lift is driven by an electro-hydraulic system. The gear pump delivers hydraulic oil to oil cylinders and pushes upwards its piston.

The piston drives the chain to raise the carriage and the lifting arms. During lifting process,

the safety teeth will automatically and firmly bite with the safety rod in the posts. Therefore, no slipping will happen in case the hydraulic system beaks down.

Safety structure:

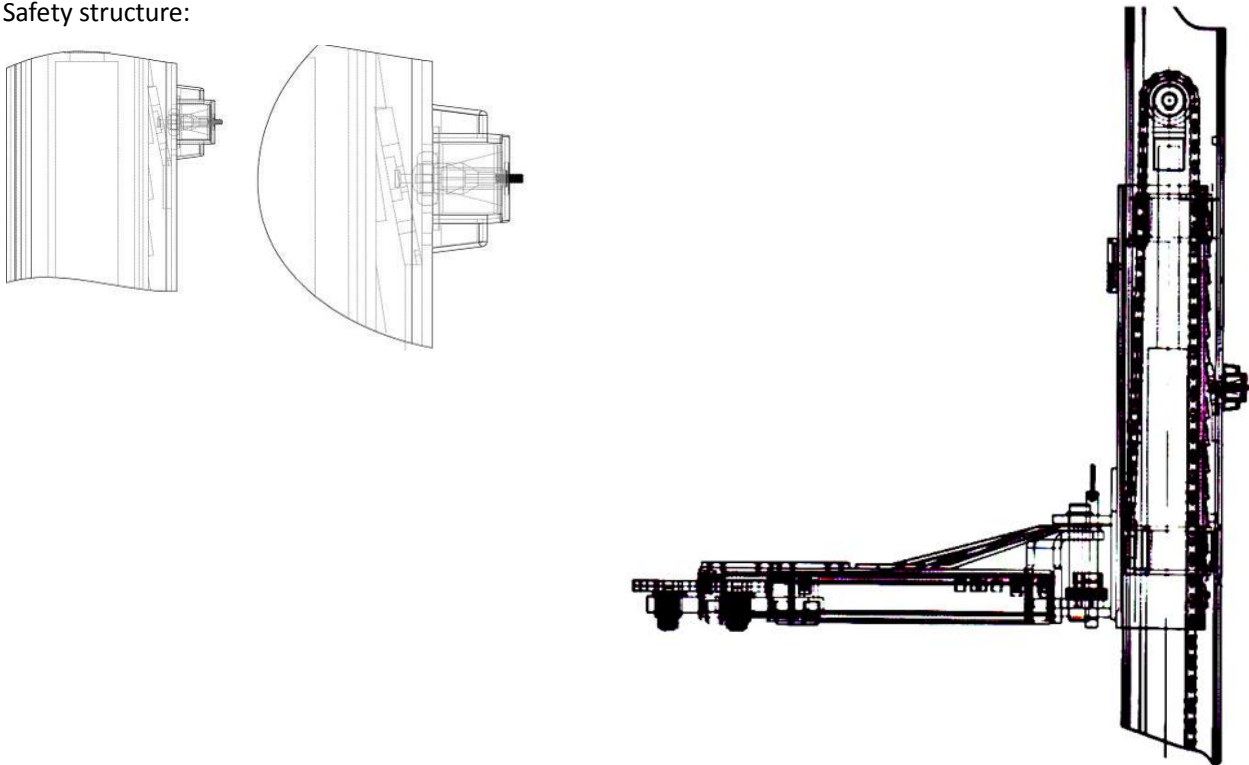

2.2 Technical data

Model	Lifting capacity	Lifting time	Lifting height	Height	Width	Width between posts
TW 242 PE B4.3	4200kg	50 Sec	1930mm	4300mm	3436mm	2850mm

2.3 Construction of the lift

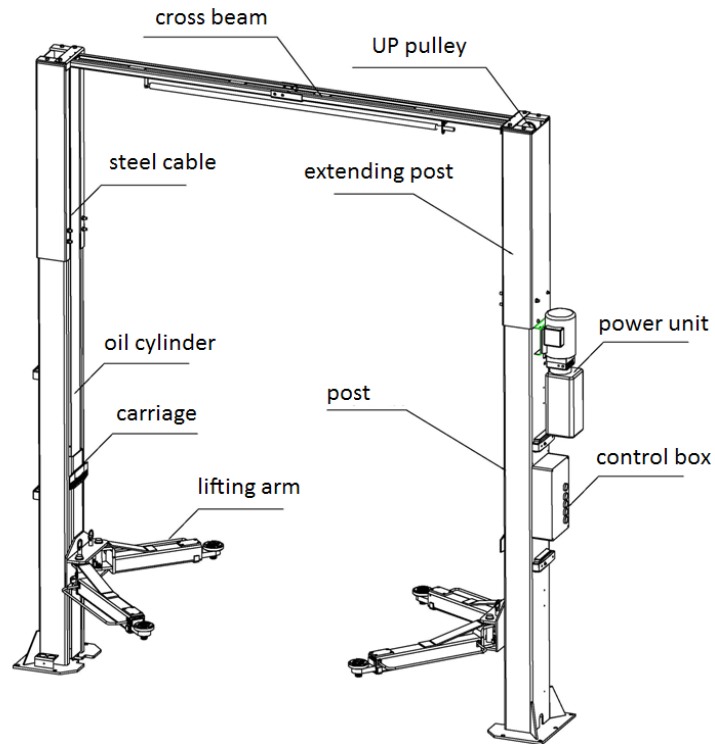

INSTALLATION INSTRUCTIONS

3.1 Preparations before installation

3.1.1 Tools and equipments needed

- ✓ Appropriate lifting equipment
- ✓ Anti-abrasion hydraulic oil.
- ✓ Rotary Hammer Drill with 3/4" drill bit.
- ✓ Chalk and tape measure, magnetic plump, 8 meters $\Phi 15$ level pipe.
- ✓ Sockets and open wrenches, a set of inside hex wrenches, cross and straight screw drivers.
- ✓ Hammer, 4pounds, sharp nose pliers, $\Phi 17, \Phi 19, \Phi 22$ socket spanners.

3.1.2 List for parts checking ---Annex 1 (Packing list)

Unfold the package and check if any parts missed as per Annex 1. Do not hesitate to contact us in case any parts missed, but if you do not contact us and insist installing upon the lack of some parts, FRIEND as well as our dealers will not bear any responsibility for this and will charge for any parts subsequently demanded by the buyer.

3.1.3 Ground conditions

The lift should be fixed on a smooth and solid concrete ground with its strength more than 3000psi, tolerance of flatness less than 5mm and minimum thickness of 200mm. In addition, newly built concrete ground must undergo more than 28days' cure and reinforcement.

3.2 Precautions for installation

- 3.2.1 Make sure the two posts stand paralleled and are vertical to the ground. No slanting.
- 3.2.2 Joints of oil hose and steel cable must be firmly connected in order to avoid the looseness of steel cable and oil leakage
- 3.2.3 All bolts should be firmly screwed up.
- 3.2.4 Do not place any vehicle on the lift in the case of trial running.

3.3 Installation

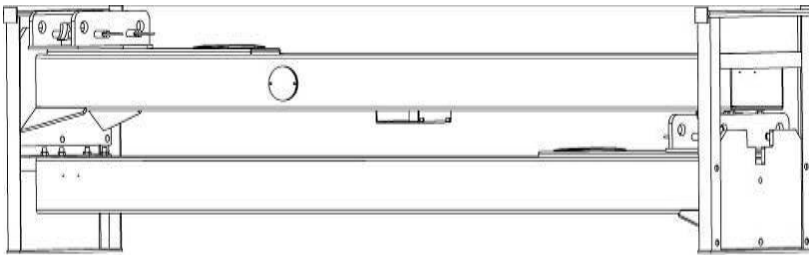

Step 1: Remove the packaging, take out the carton for accessories.

Step 2: Firstly, put something supporting between the two posts or suspend one of the posts by a crane and then remove the bolts from the packing frame.

Attention : Please pay special attention not to let the post fall down for it may cause casualty or bring damages to the accessories fixed in the post.

Step 3: When the first post has been taken away, place something supporter under the second post and then remove the bolts from the packing frame.

Step 4: Fix the standing position for the two posts.

1. Unfold the package and decide on which post the power unit will be mounted.
2. Refer to **Annex 2** and **Annex 3** to ascertain the position for the two posts with chalk and tape measure and draw an outline of the two base plates on the ground.

Step 5: Erect and secure the post, power side post (the post on which the control box and pump assembly will be mounted) first and then the other post.

1. Drill anchor holes for expansion bolts on the ground with an electrical drill. Make sure to drill vertically.
2. Remove thoroughly the debris and dust in holes and ascertain that the posts stay right upon the circle previously marked by chalk.
3. In case the base of the post and the surface of the ground were not as smooth as required, insert a piece of washer (with proper thickness) under the base of the post to ensure the smoothness and the verticality of the post .Secure the post with expansion bolts thereafter.
4. Erect and secure the other post similarly as per step, 1, 2, and 3.

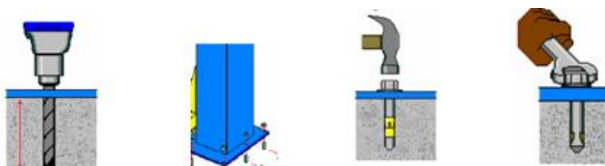

Step6: Install cross beam and hang on the top roof protection bumper.

1. **Connect the inside and outside cross beam**
2. **Connect the cross beam to the two post.**

Step7: Connect steel cables.

1. Route and fix according to the following diagram of steel cable connection.
2. Raise carriages on both sides approximately 800mm above the ground. Carriages must be on the same height from the floor.
3. Make sure that the mechanical safety locks in each post are fully engaged before attempting to route cables.
4. After the cable being fixed, adjust and make the cable at both sides be with the same tightness which could be judged by the sound emitted during lifting process. Make judge and adjustment after trial running.
5. Grease after being fixed. (It is a must.)

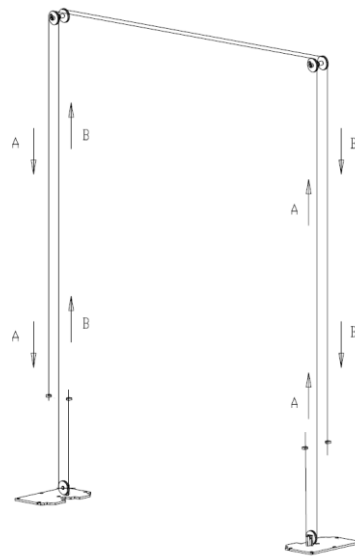

Step8: Connect oil hoses.

1. Mount the power unit onto the power side post.

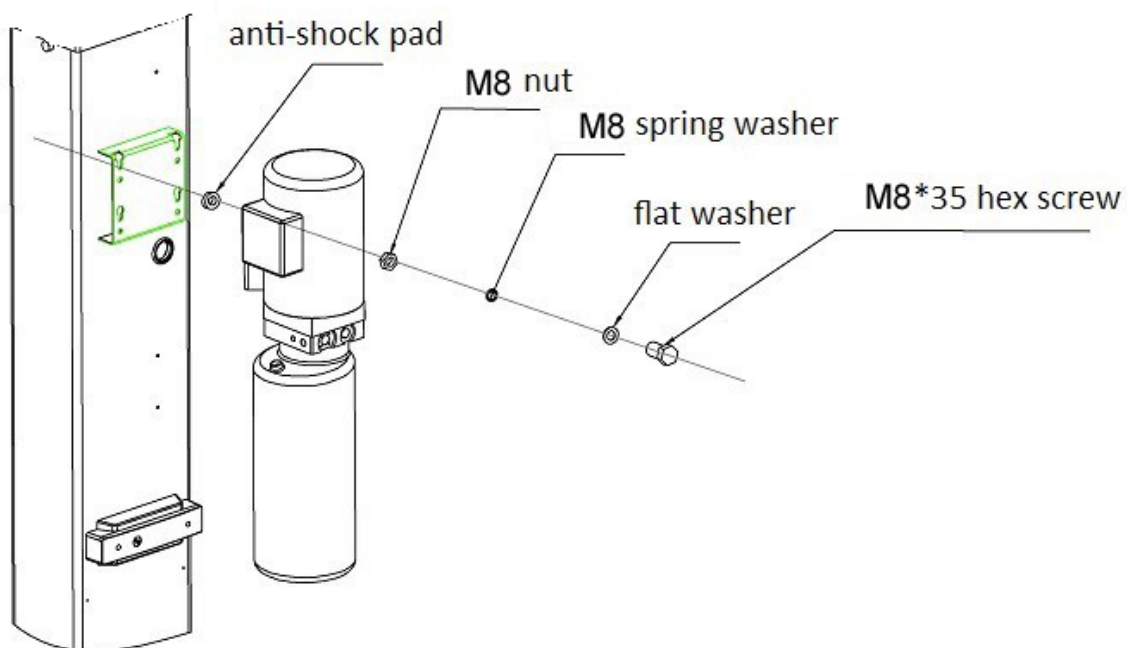

Step9. Connect oil hoses

1. Connect oil hoses according to the drawing
2. Keep the connector clean during the connection.

Step10: Fix the electromagnets.

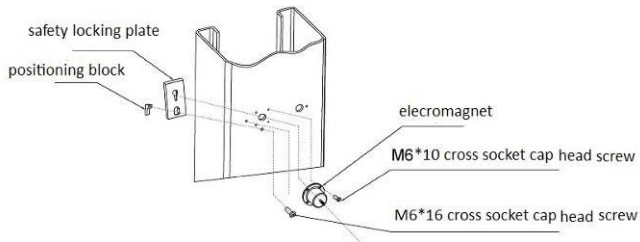

Step11: Connect wires.

Attention: Only licensed electricians are allowed to carry out electrical connection.

1. Mount the control box on to the power side post.

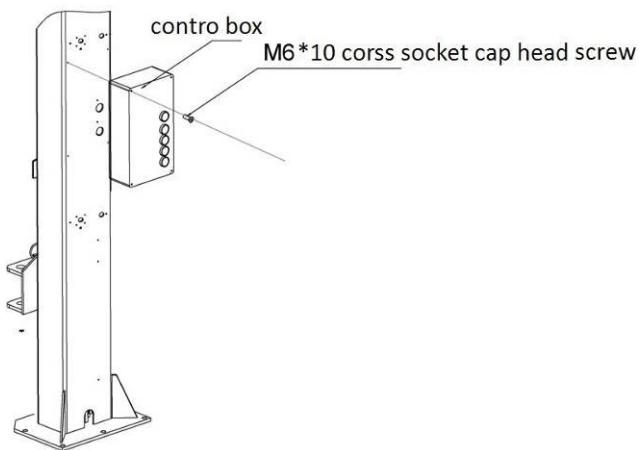

2. Connect the limit switch fixed inside the power-side post.
3. Connect the limit switch fixed at the cross beam.
4. Connect wires of electromagnet

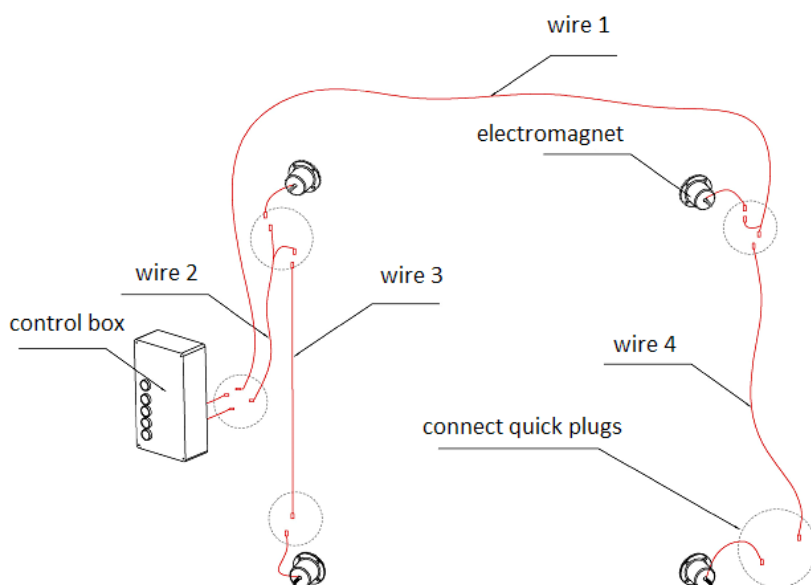

5. Connect solenoid valve, motor wire and power supply cable .

Technical changes for purposes of a technical advancement as well as deviation in colour, errors and printing mistakes are reserved.

Step12: Install lifting arms.

Connect the lifting arms and the carriage by shafts.

Step13: Connect power supply and do trial running.

Do refer to the operation instructions in advance and keep in mind that no vehicle left on the lift in the process of trial running.

1. Assure all the connections are in good condition and connect the power supply.
2. Usually it needs 13 liters of hydraulic oil. Firstly, fill about 10Ls into the oil tank to run the lift up and down for 2 or 3 times and then fill into the rest 3Ls. It is suggested to use 32#anti-abrasion hydraulic oil for winter, 46# for summer.
3. Vent air remained the oil cylinder. Screw loose the nut on top of the oil cylinder and slightly press the UP button until oil gets out. Screw the nut tight thereafter.

Step13: Fix feet protection fenders, chain protection clothes, electro-magnet protection covers, door-opening protections and lifting trays.

3.4 Items to be checked after installation.

S/N	Check items	YES	NO
1	Are the posts vertical to the floor?		
2	Are the two posts paralleled?		
3	Is the oil hose well connected?		
4	Is the steel cable well connected?		
5	Are all lifting arms well fixed?		
6	Are electrical connections right?		
7	Are the rest joints firmly screwed?		
8	Are all items need lubricating added with grease?		

OPERATION INSTRUCTIONS

4.1 Precautions

- 4.1.1 Check all the joints of oil hose. Only when there is no leakage, the lift can start work.
- 4.1.2 The lift, if its safety device malfunctions, shall not be used.
- 4.1.3 The machine shall not lift or lower an automobile if its center of gravity is not positioned midway of the lifting arms. Otherwise, the FRIEND as well as our dealers will not bear any responsibility for any consequence resulted thereby.
- 4.1.4 Operators and other personnel concerned should stand in a safety area during lifting and lowering process.
- 4.1.5 When lifting arms rise to the desired height, switch off the power at once to prevent any mal-operation done by unconcerned people.
- 4.1.6. Make sure the safety lock of the lift is engaged before start working under the vehicle and no people under the vehicle during lifting and lowering process.

4.2 Flow chart for operation

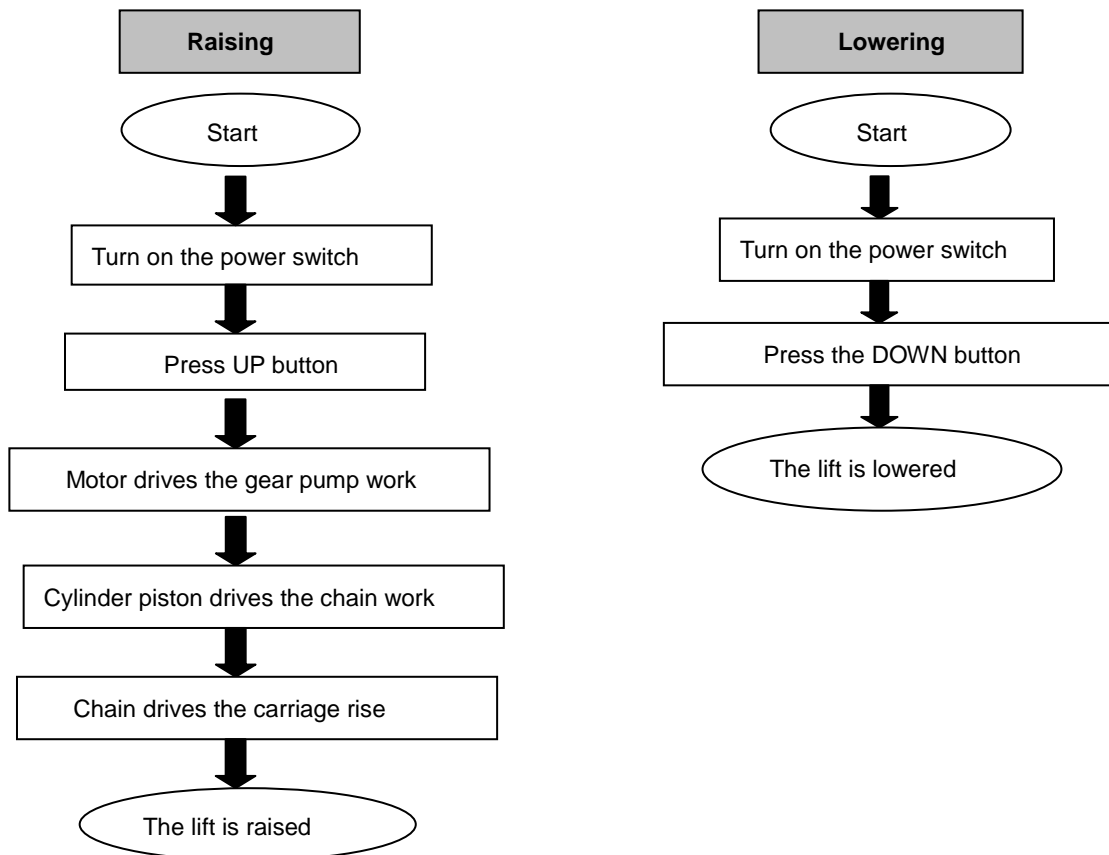

4.3 Operation instructions

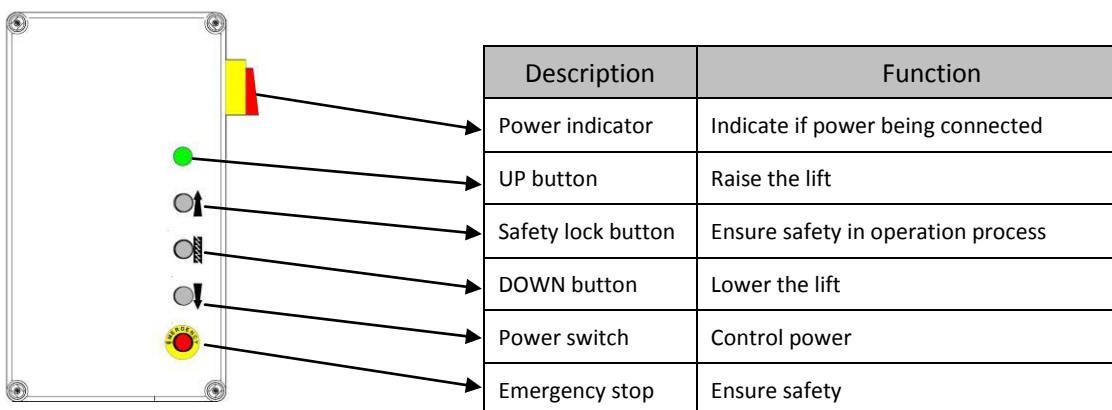

Raise the lift

1. Make sure that you have read and understood the operation manual before operation.
2. Park the vehicle between two posts.
3. Adjust lifting arms until they reach the supporting positions of the vehicle and make sure the gravity of vehicle located midway of four lifting arms.
4. Switch on and insure to operate as per requirements on the nameplate attached.
5. Press the "UP" button on the control box until pads of lifting arms touched the prop-position of vehicle.
6. Keep on raising the vehicle to let it have a bit clearance from the ground and check again its stability.
7. Raise the vehicle to the desired height, check it is safe or not, press the "Safety Lock" button on the control panel to have the safety lock engaged, turn off the power and then perform maintenance or repair work underneath.

Lower the lift

1. Switch on.
2. Press the "DOWN" button on the control box. Meanwhile the lifting arms automatically go upwards about 5CM to release the safety lock. Then lifting arms start lowering.
3. After lifting arms lower to the lowest position, pull them out from under the vehicle and clear up all the obstacles.
4. Drive the vehicle away.

TROUBLE SHOOTING

ATTENTION: If the trouble could not be fixed by yourself, please do not hesitate to contact us for help .We will offer our service at the earliest time we can. By the way, troubles could be judged and solved much faster if more details or pictures could be provided.

TROUBLES	CAUSE	SOLUTION
Abnormal noise	Abrasion exists on insider surface of the posts.	Grease the inside of the post.
	Trash in the post.	Clear the trash
Motor does not run and will not rise	The wire connection is loose.	Check and make a good connection.
	The motor is blown.	Replace it.
	The limit switch is damaged or the wire connection is loose.	Connect it or adjust or replace the limit switch.
Motor runs but will not raise	The motor run reversely.	Check the wire connection.
	Overflow valve is loose or jammed.	Clean or adjust it.
	The gear pump is damaged.	Replace it.
	Oil level is too low.	Add oil.
	The oil hose became loose or dropped off.	Tighten it.
	The cushion valve became loose or jammed.	Clean or adjusts it.
Carriages go down slowly after being raised	The oil hose leaks.	Check or replace it.
	The oil cylinder is not tightened.	Replace the seal.
	The single valve leaks.	Clean or replace it.
	E-magnetic valve fails to work well.	Clean or replace it.
	Steel cable is loose or not with same tightness	Check and adjust the tightness.
Raising too slow	The oil filter is jammed.	Clean or replace it.
	Oil level is too low.	Add oil.
	The overflow valve is not adjusted to the right position.	Adjust it.
	The hydraulic oil is too hot (above 45°) .	Change the oil.
	The seal of the cylinder is abraded.	Replace the seal.
	Inside surface of the posts is not well greased.	Add grease.
Lowering too slow	The throttle valve jammed.	Clean or replace.
	The hydraulic oil is dirty.	Change the oil.
	The anti-surge valve jammed.	Clean it.
	The oil hose jammed.	Replace it.
The steel cable is abraded	No grease when installation or out of lifetime	Replace it.

MAINTENANCE

Easy and low cost routine maintenance can ensure the lift work normally and safely. Following are requirements for routine maintenance. Frequency of routine maintenance is determined by working condition and frequency.

The following parts need lubrication.

S/N	Name
1	UP pulley
2	Steel cable
3	Slider
4	Shaft
5	Arm lock
6	Lifting arm
7	Lifting tray
8	DOWN pulley

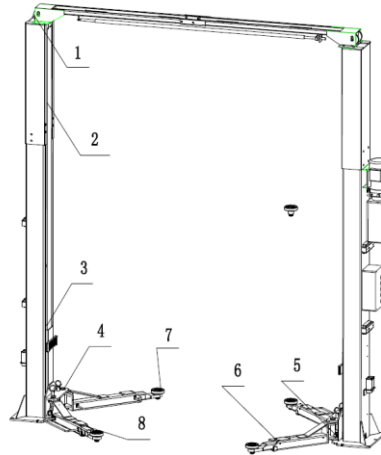

6.1 Daily checking items before operation

The user must perform daily check. Daily check of safety lock system is very important – the discovery of device failure before action could save time and prevent great loss, injury or casualty.

- Before operation, judge whether the safety locks are engaged by sound.
- Check whether oil hose well connected and whether it leaks or not.
- Check the connections of chain and steel cable and check the power unit.
- Check whether expansion bolts are firmly screwed.
- Check if arm lock works well or not.

6.2 Weekly checking items

- Check the flexibility of moving parts.
- Check the working conditions of safety parts.
- Check the amount of oil left in the oil tank. Oil is enough if the carriage can be raised to highest position. Otherwise, oil is insufficient.
- Check whether expansion bolts are firmly screwed.

6.3 Monthly checking items

- Check whether expansion bolts are firmly screwed.
- Check the tightness of the hydraulic system and screw firm the joints if it leaks.
- Check the lubrication and abrasion circumstance of axial pins, carriages, lifting arms and other related parts and replace in time with new ones if they failed to work well.
- Check the lubrication and abrasion circumstance of steel cable.

6.4 Yearly checking items

- Empty the oil tank and check the quality of hydraulic oil.
- Wash and clean the oil filter.

If the above maintenance suggestions are strictly followed, the lift will always keep in a good working condition and meanwhile accidents could be avoided to a large extent.

ANNEX

Annex 1, Packing List of the whole lift

S/N	Material #	Name	Drawing#	Qty	Property
1		Power-side post	FL-8214E-A1	1	Assembly
2		Post	FL-8214E-A2	1	Assembly
3		Carriage	FL-8214E-A3	2	Assembly
4		Power unit		1	Assembly
5		Oil cylinder	FL-8224-A4-B3	2	Assembly
6		Control box		1	Assembly
7		Electromagnet package	FL-8224E-A1-B4	1	Assembly
8		Steel cable	FL-8214-A6 L=10870	2	Assembly
9		Long arm	FL-8224-A7		Assembly
10		Extending post	FL-8214-A1-B2	2	Powder-coating
11		Cross beam (in)	FL-8214-A3-B1	1	Powder-coating
12		Cross beam (out)	FL-8214-A3-B2	1	Powder-coating
13		Short lifting arm	FL-8224-A8	1	Assembly
14		Roof protection bar	FL-8214-A3-B7	1	Powder-coating
The carton includes the following					
15		Lifting tray	FL-8224-A7-B3	4	Assembly
16		Long fender	FL-8224-A7-B4	2	Assembly
17		Short fender	FL-8224-A8-B3	2	Assembly
18		Height adapter	FL-8224-A15	4	Zinc-plating
19		Shaft	FL-8224-A12	4	Zinc-plating
20		Safety locking plate	FL-8224E-A1-B2	4	Zinc-plating
21		Electromagnet protection cover	FL-8224E-A1-B5	4	ABS
22		Positioning block	FL-8224E-A1-B3	4	Zinc-plating
23		Hose protection cover	FL-8224E-A1-B8	7	Powder-coating
24		Chain protection cloth	FL-8214-A7	2	Assembly
25		Rod of chain protection cloth	FL-8224-A13	4	Zinc-plating
26		Rubber oil hose L=500	FL-8214-A4-B1	1	Assembly
27		Protection rubber pad	FL-8224-A3-B7	2	Rubber
28		Hex head full swivel screw	M8*35	4	Standard
29		Hex head full swivel screw	M14*30	1	Standard
30		Hex head full swivel screw	M14*25	16	Standard
31		Hex head full swivel screw	M8*12	5	Standard
32		Hex socket button head screw	M8*35	8	Standard
33		Cross socket cap head screw	M6*10	24	Standard
34		Cross socket cap head screw	M6*30	14	Standard
35		Cross socket cap head screw	M6*8	10	Standard
36		Cross socket cap head screw	M6*16	4	Standard
37		Cross socket flat head screw	M8*16	4	Standard
38		Flat washer	Φ 6	9	Standard
39		Flat washer	Φ8	4	Standard
40		Flat washer	Φ14	21	Standard
41		Spring washer	Φ8	4	Standard
42		Spring washer	Φ14	21	Standard
43		Hex nut	M6	8	Standard

Technical changes for purposes of a technical advancement as well as deviation in colour, errors and printing mistakes are reserved.

S/N	Material #	Name	Drawing#	Qty	Property
44		Hex nut	M8	4	Standard
45		Hex nut	M14	21	Standard
46		Circlip	Ø38	4	Standard
47		Expansion bolt	M18*160	10	Standard

Annex2, Overall diagram

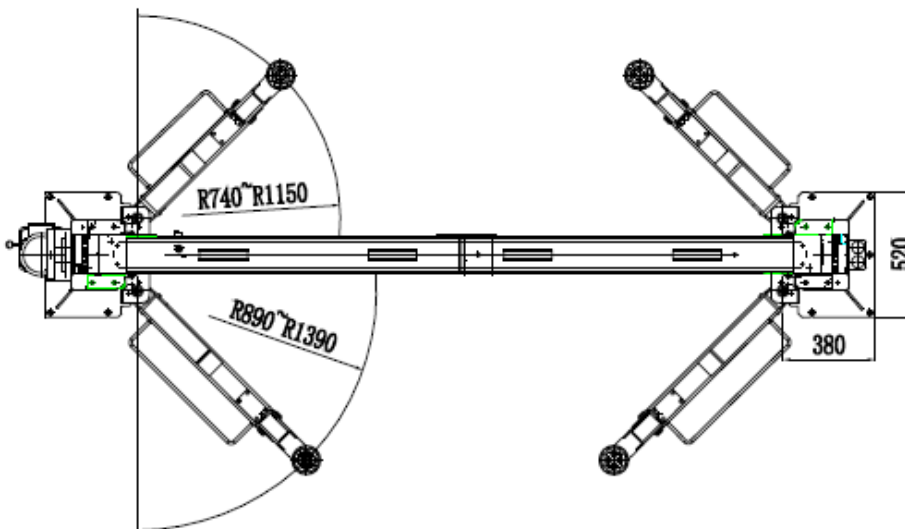
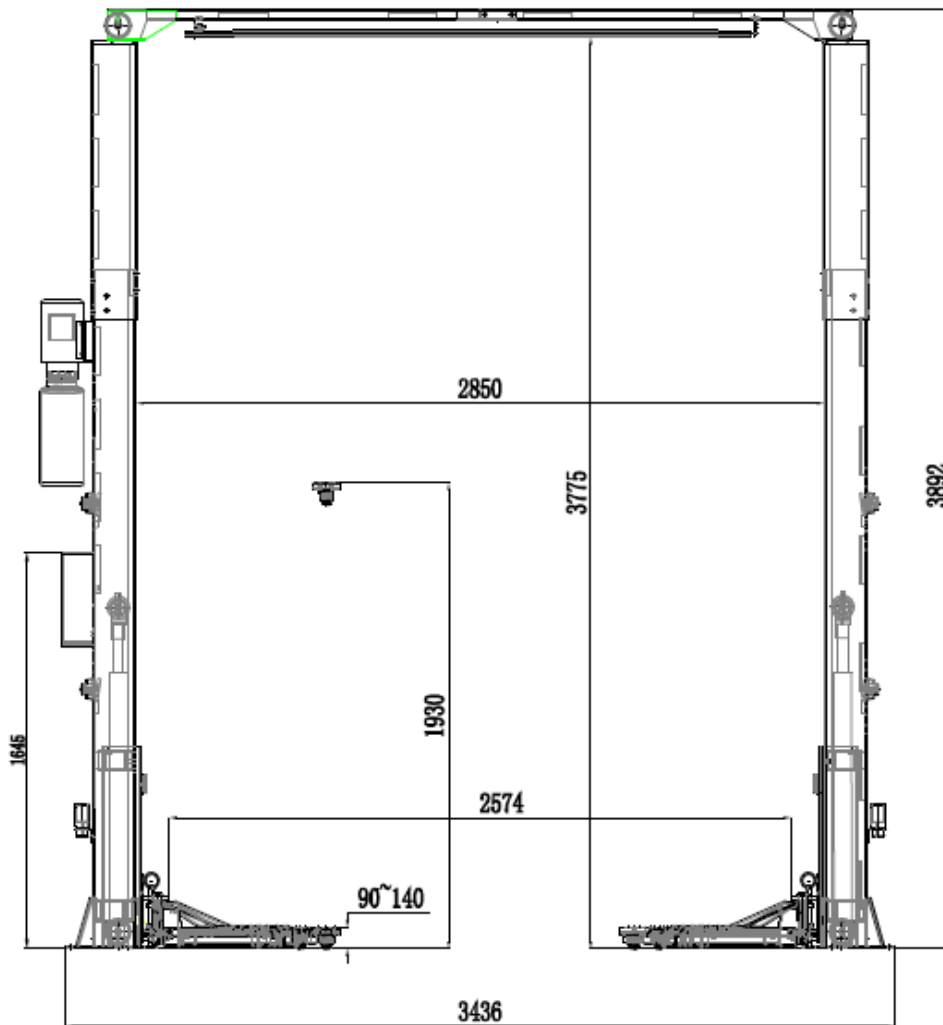

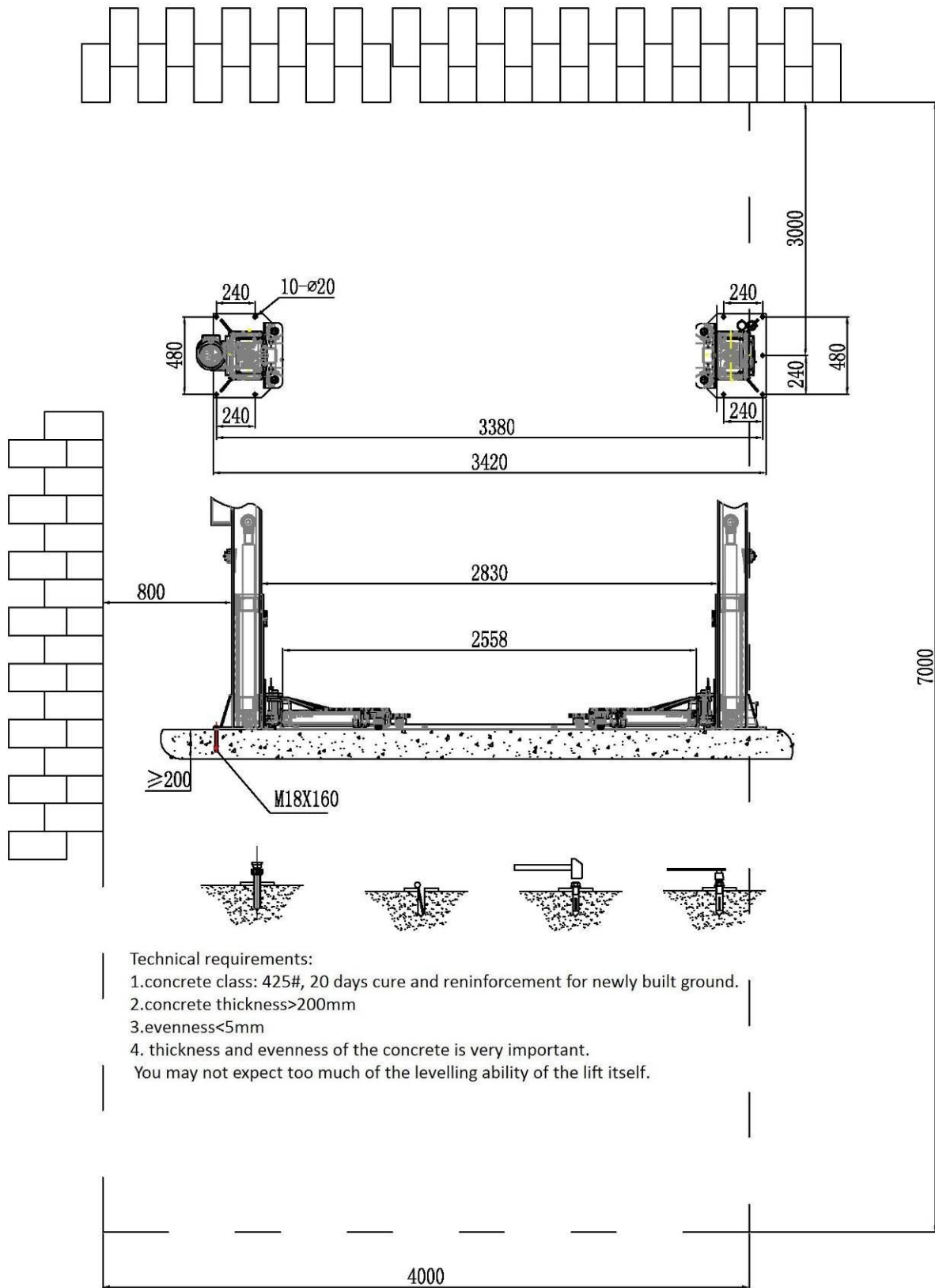

Requirements for the concrete floor:

- Concrete C20 / 25 according to DIN 1045-2 (Previously known as DIN 1045 concrete B25).
- Horizontal, accuracy of flatness smaller than 5 mm (0.2”).
- New concrete must dry for 28 days.

Foundation dimensions:

- Ideally, it's better to cover the whole area in concrete C20 / 25, 200 mm (up to 4 t) or 250 mm thick (5 t).

Minimum requirements: 2-Post lift 4 t:

4 m x 3 m x 0,2 m

(13 ft. x 10 ft. x 8 in.)

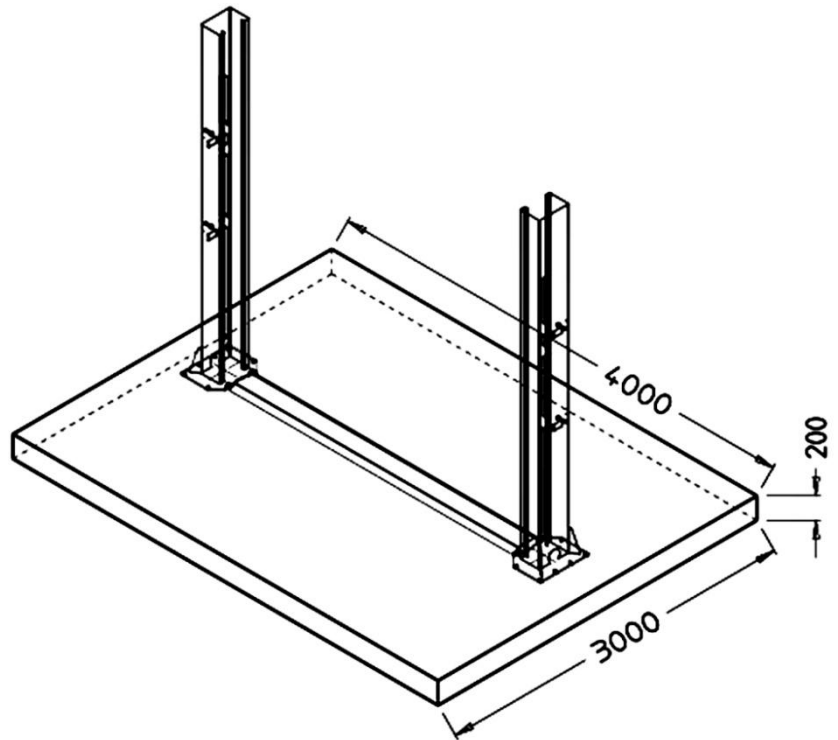

alternativ H-form

alternativ Block-form

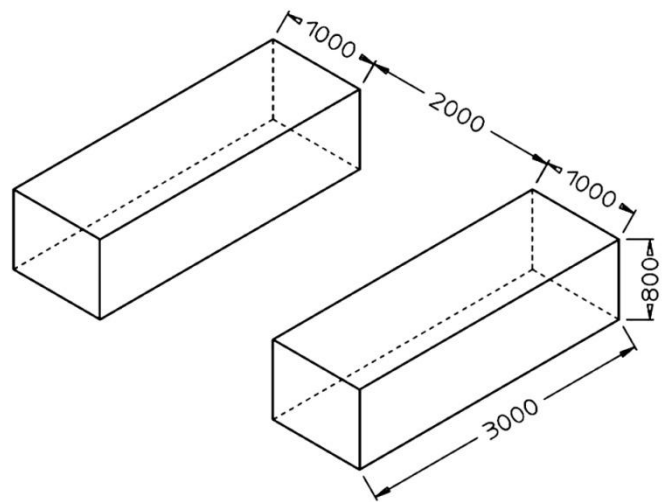
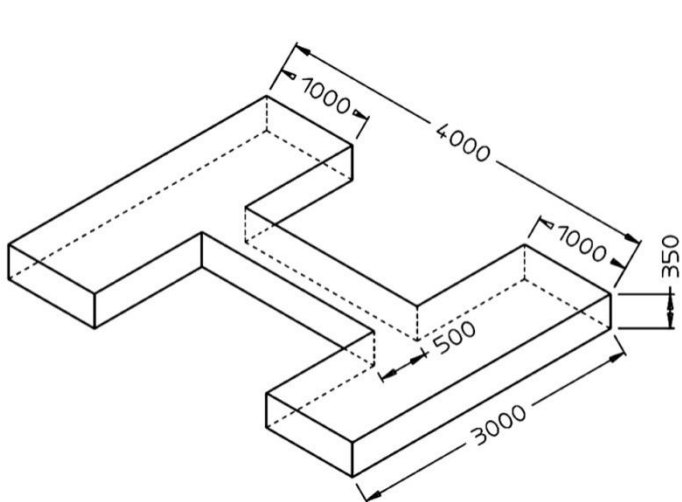

□ **Other requirements:**

- The surrounding ground must be suitable for the load, for example, no sand asphalt, etc..
- If in doubt, the foundation should always be checked by a structural engineer.

In case of frost, please note the following:

In cases of freezing the concrete should have exposure class XF4.

Thus, the following minimum requirements for the concrete in frost conditions:

Exposure class XF4

Maximum w / c: 0.45

Minimum compressive strength: C30 / 37 (instead of C20 / 25)

Minimum cement content 340 kg / m³

Minimum air content: 4.0%

It must however be noted that the lifting platforms not for use outdoors

The main switch corresponds to IP54, but remaining electrical parts, Motors and limit switches are designed to a maximum of IP44.

Expansion bolts

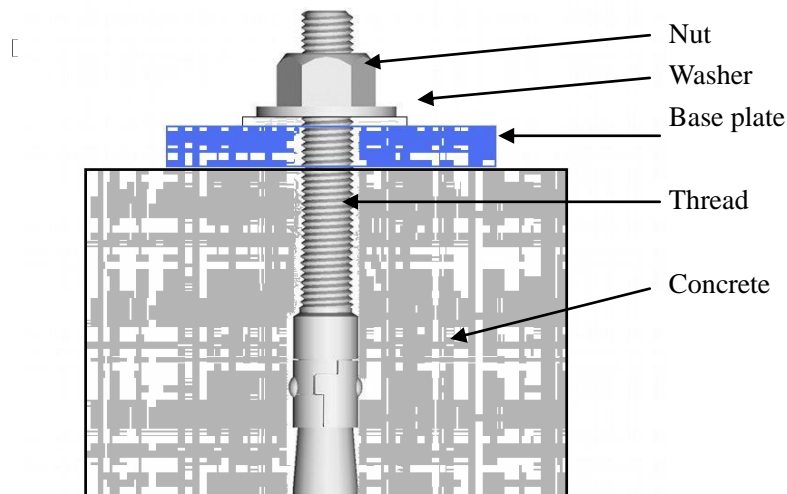

Expansion bolts should be tightened to 120 Nm.

Annex4, Wiring diagram

Single phase

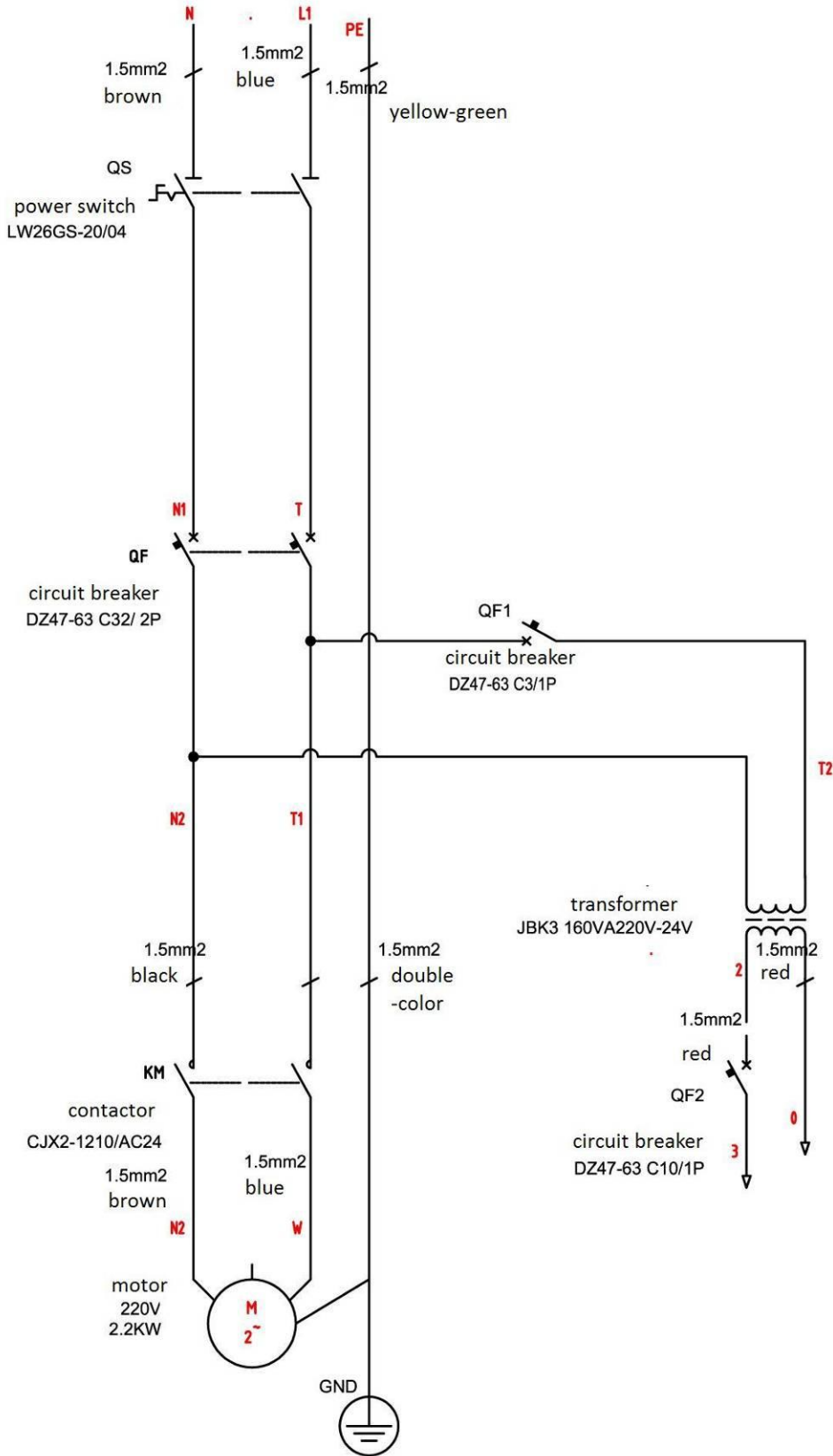

Three phase

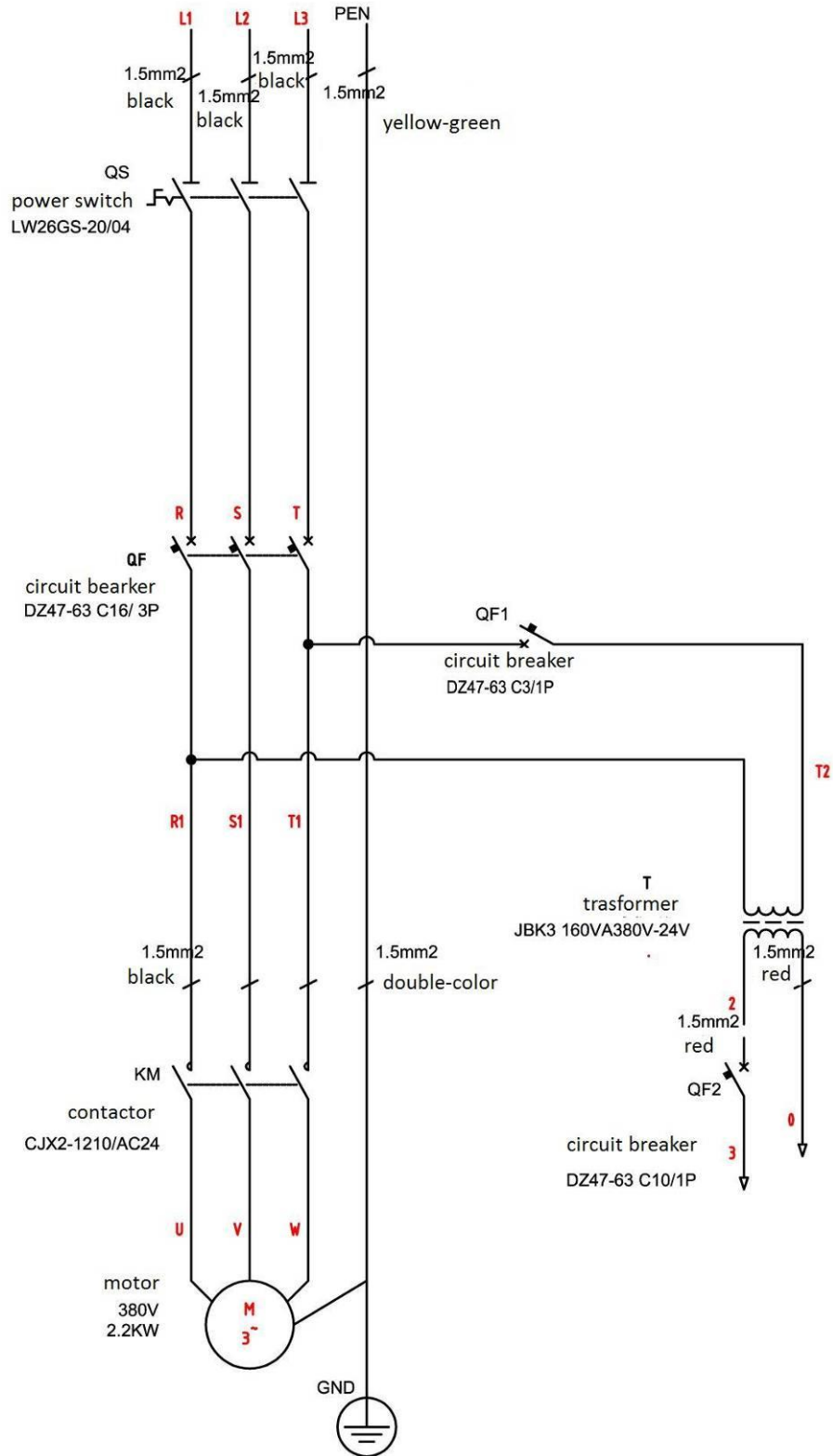

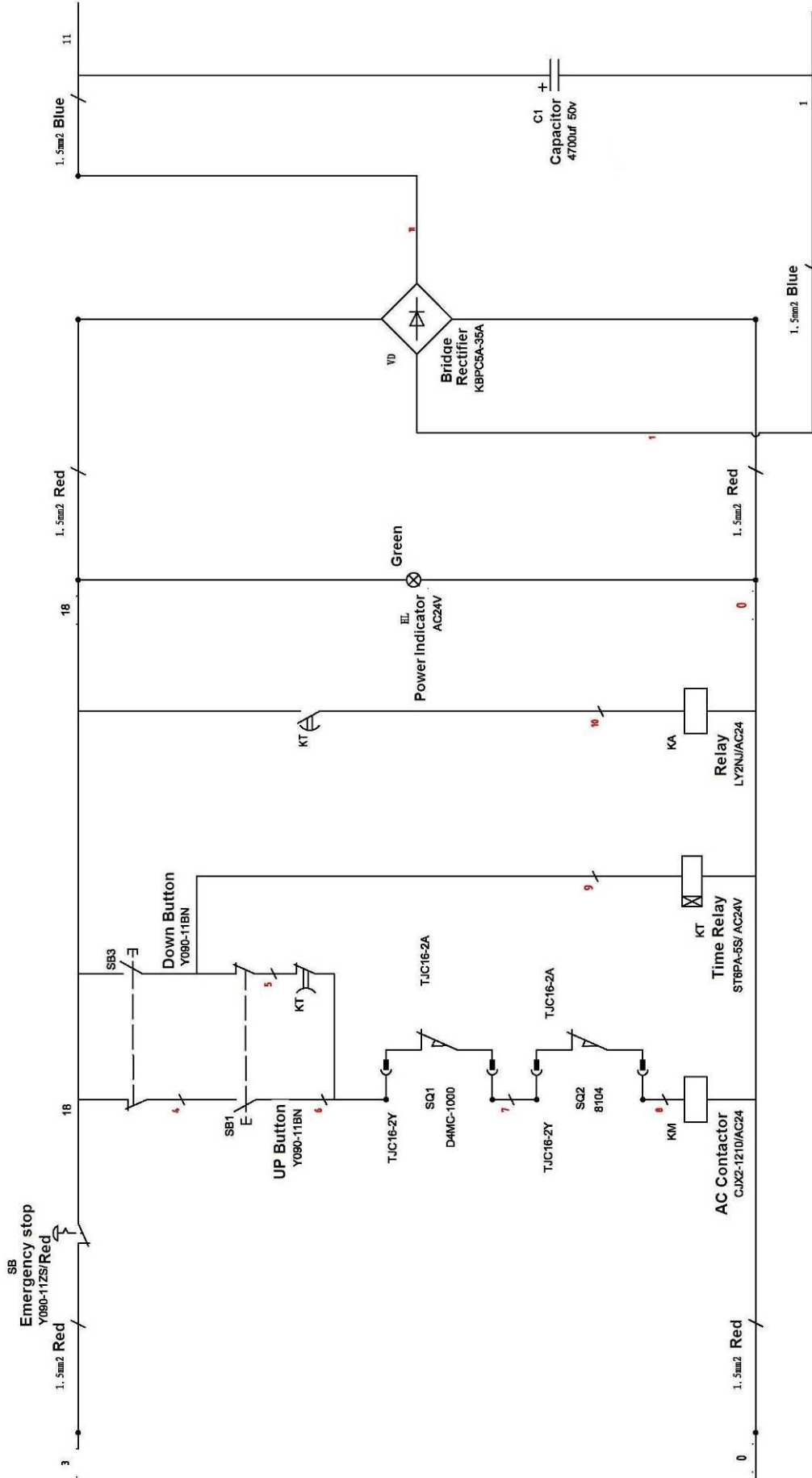

Technical changes for purposes of a technical advancement as well as deviation in colour, errors and printing mistakes are reserved.

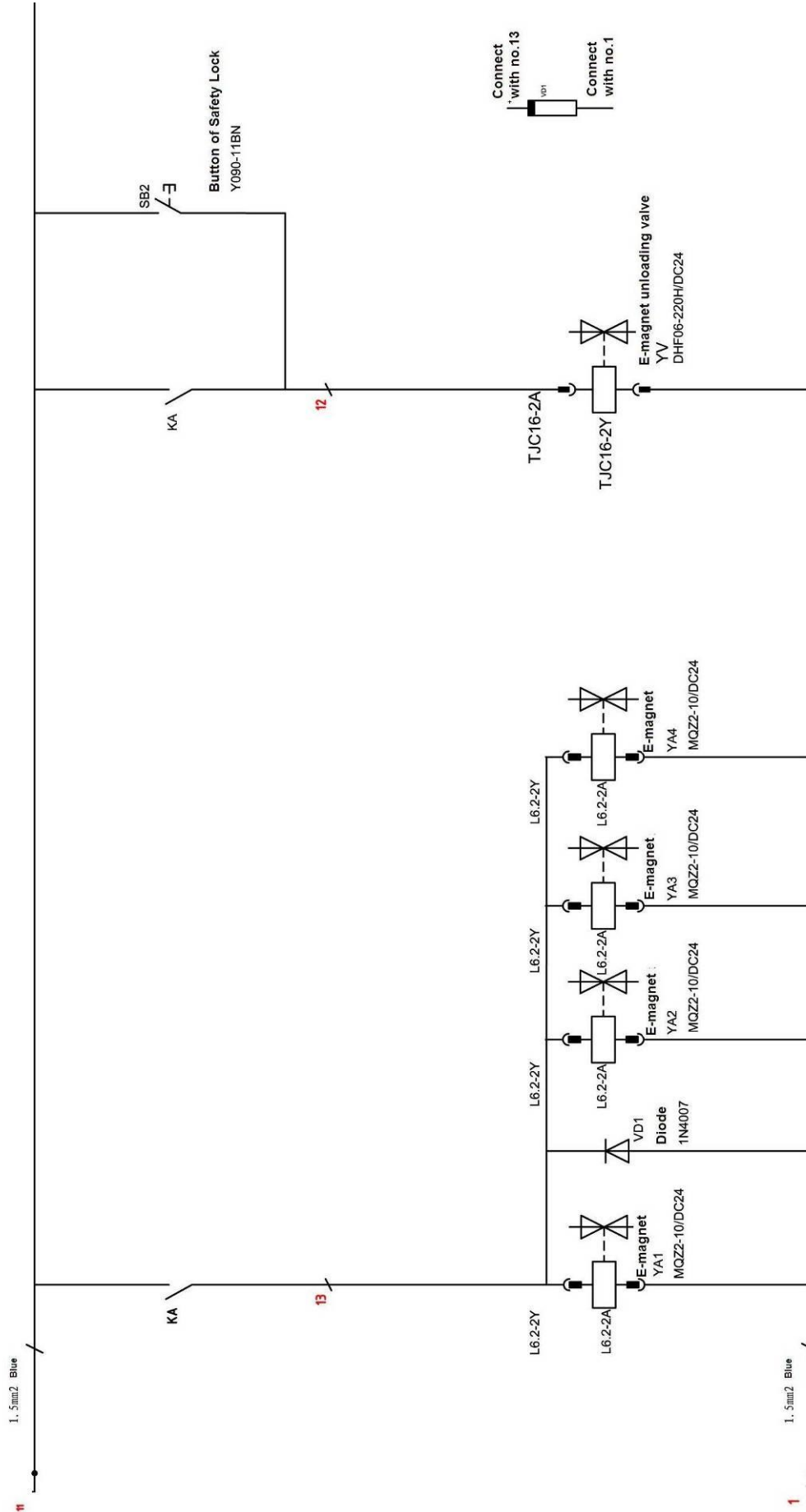

Technical changes for purposes of a technical advancement as well as deviation in colour, errors and printing mistakes are reserved.

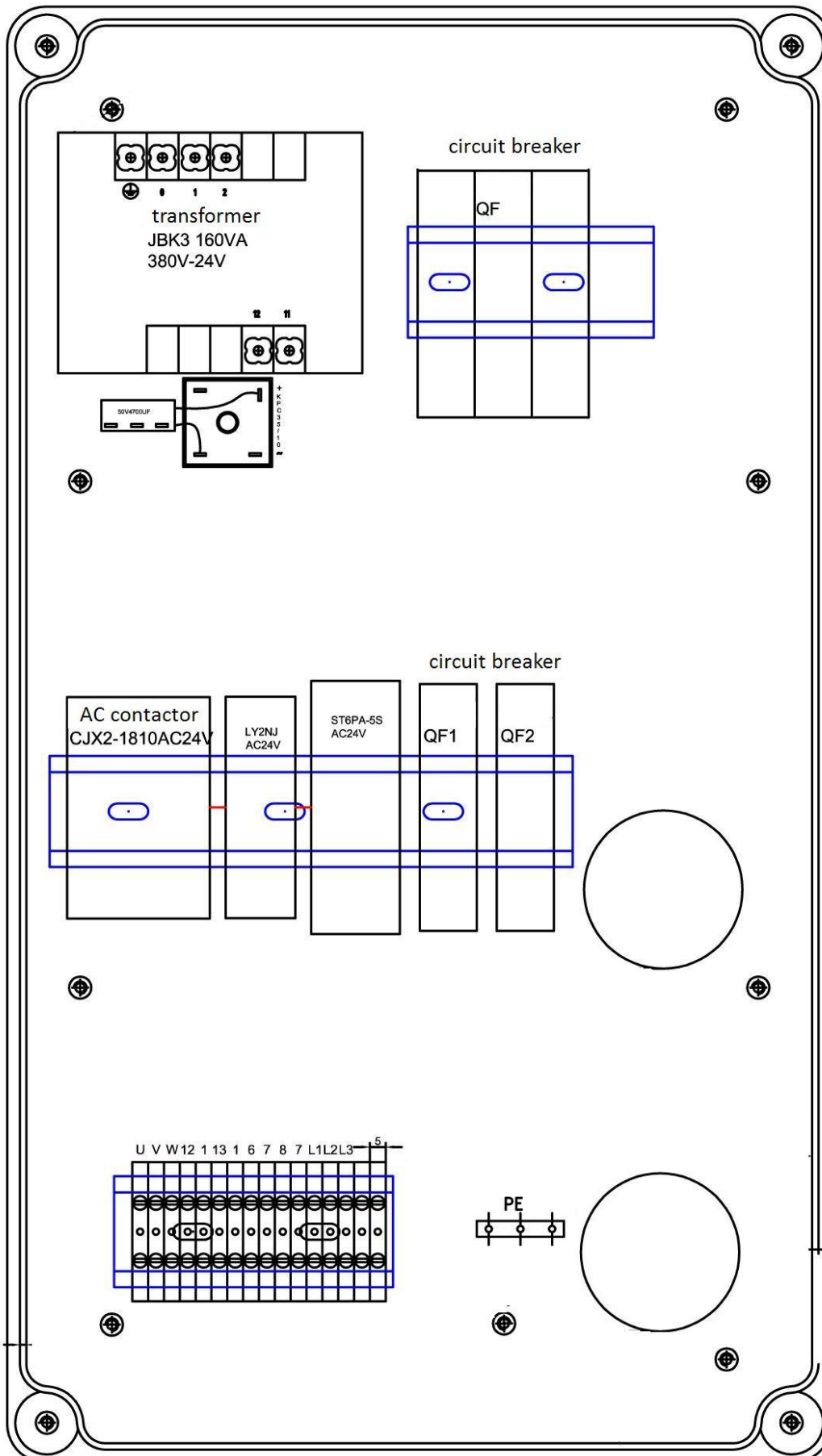

Annex5, Hydraulic working system

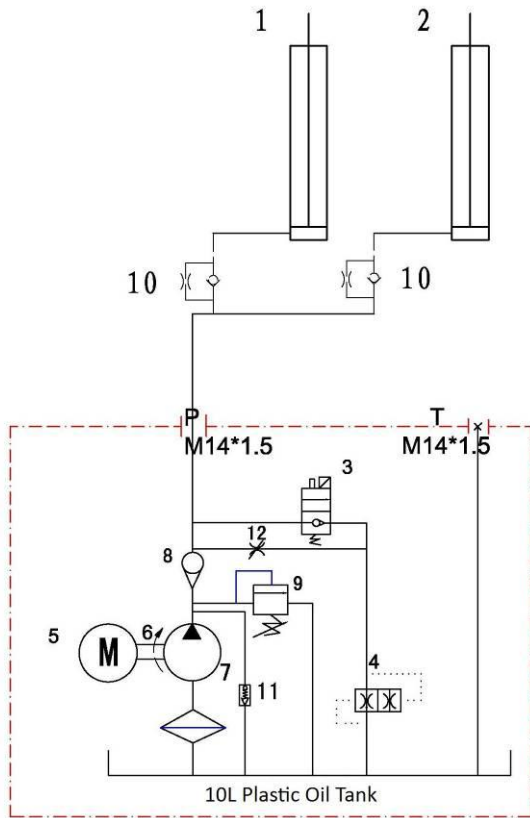

- 1. Driving cylinder
- 2. Assistant cylinder
- 3. Electro-unloading valve
- 4. Lowering throttle valve
- 5. Motor
- 6. Coupling
- 7. Gear pump
- 8. Single-way valve
- 9. Overflow valve
- 10. Anti-surge valve
- 11. Cushion valve
- 12. Emergent unloading valve

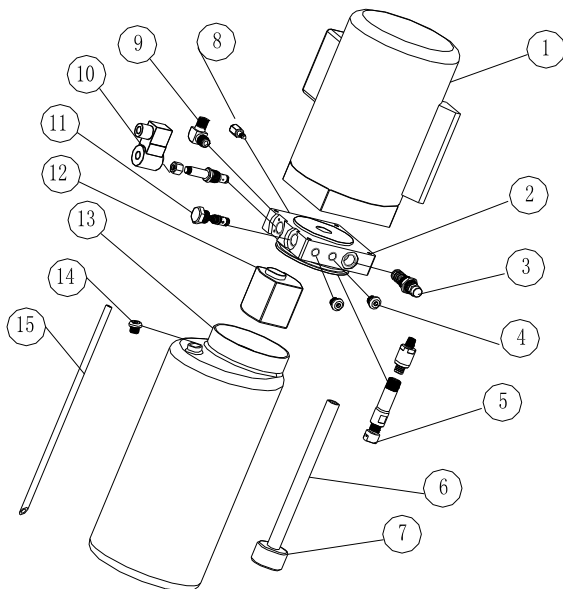

S/N	Name	Qty
1	Motor	1
2	Hydraulic block	1
3	Overflow valve	1
4	Removable plug	2
5	Cushion valve	1
6	Oil absorbing pipe	1
7	Oil filter	1
8	Throttle valve	1
9	Oil pipe tie-in	1
10	E-magnetic unloading valve	1
11	One-way valve	1
12	Gear pump	1
13	Plastic oil tank	1
14	Oil tank cover	1
15	Oil back pipe	1

Annex6, Separated drawings for the lift

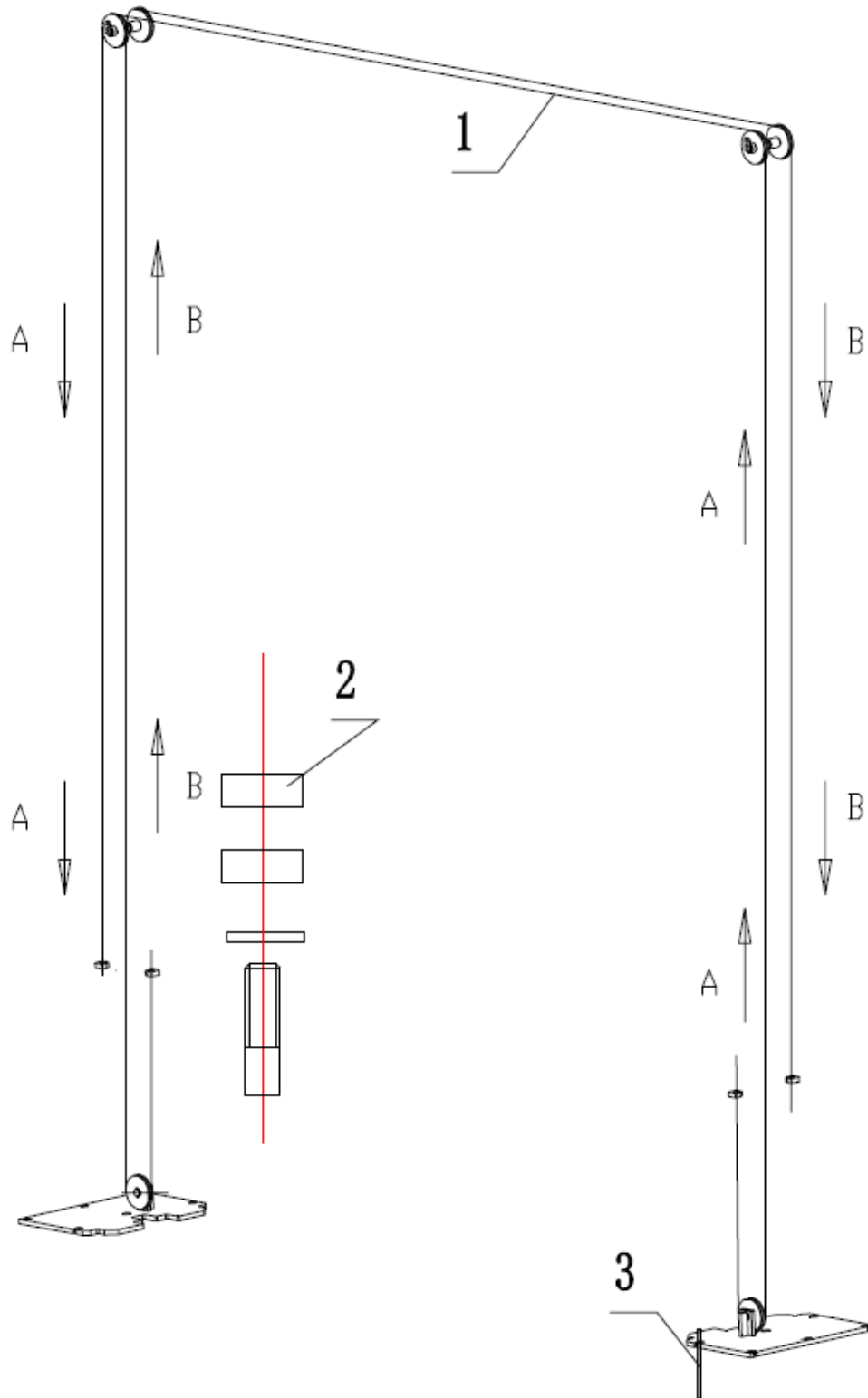

S/N	Material #	Name	Drawing#/Spec.	Qty	Property	Note
1		Steel cable L=10870mm	FL-8214E-A6	2	Assembly	
2		Hex nut M16	GB/T610-2000	8	Standard	
3		Expansion bolt M18*180		10	Standard	

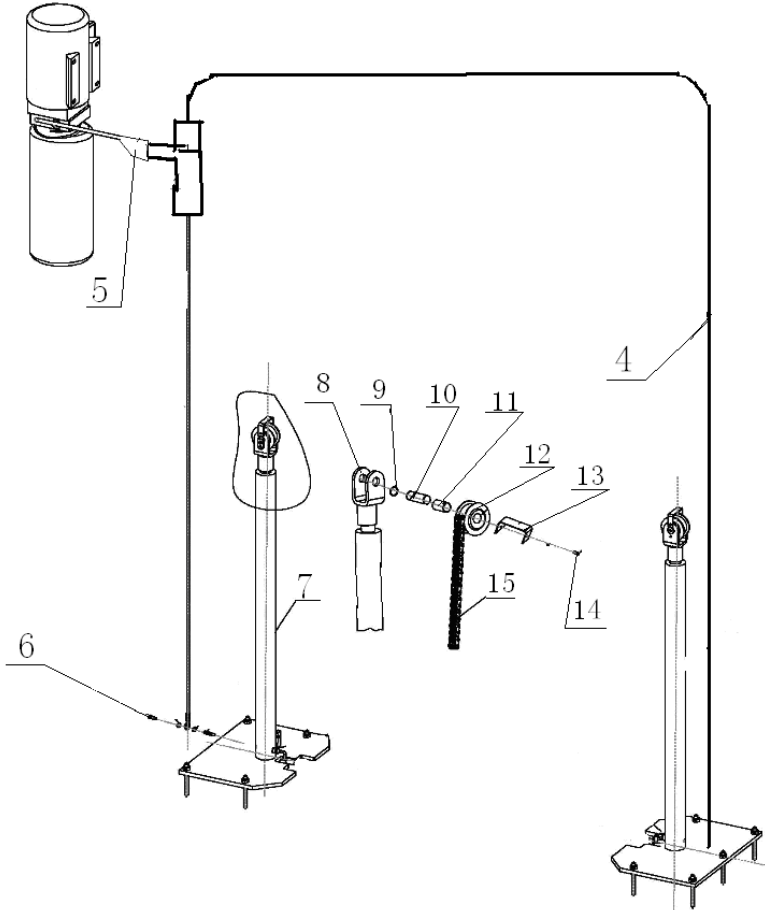

S/N	Material #	Name	Drawing#/Spec.	Qty	Property	Note
4		Oil Hose L=2900		1	Assembly	
5		Short oil hose L=500		1		
6		Connector		1		
7		Oil cylinder	FL-8224-A4-B2	1	Assembly	
8		Cylinder fixing ring	FL-8224-A4-B9	2	Q235A	
9		Hex head full swivel screw	GB/T894. 2-1986	4	Standard	
10		Chain shaft	FL-8224-A4-B11	2	Q235A	
11		Shaft 2548	SF-1	2	Assembly	
12		Chain wheel	FL-8224-A4-B10	2	Assembly	
13		U shape plate	FL-8224-A4-B12	2	Assembly	
14		Anex screw M6*10	GB/T70. 1-2000	4	Copper	
15		Chain	LH1234-127LGB/6074-1995	2	Assembly	

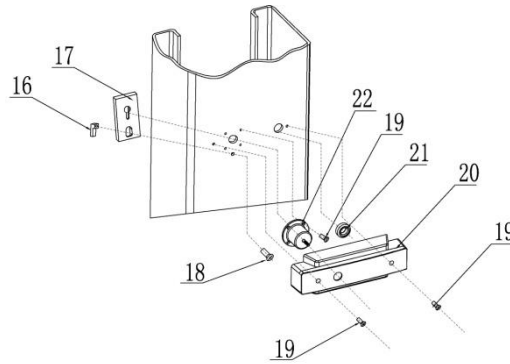

S/N	Material #	Name	Drawing#/Spec.	Qty	Property	Note
16		Positioning block	FL-8224E-A1-B3	4	Q235A	
17		Safety locking plate	FL-8224E-A1-B2	4	Q235A	
18		Cross socket cap headed screw M6*16	GB/T818-2000	4	Standard	
19		Cross socket cap headed screwM6*10	GB/T818-2000	24	Standard	
20		Electromagnet protection cover	FL-8224E-A1-B5	4	Plastic	
21		Φ20 hose protection ring	FL-8224-A1-B6	4	Rubber	
22		Electromagnet (small)	FL-8224E-A1-B4	4	Assembly	

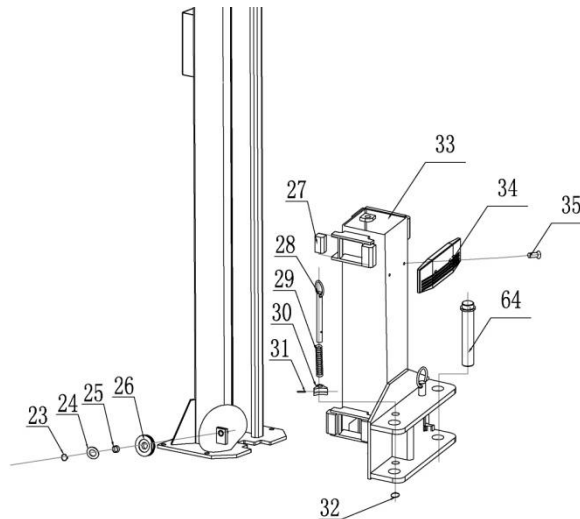

S/N	Material #	Name	Drawing#/Spec.	Qty	Property	Note
23		Circlip φ25	GB/T894.2-1986	2	Standard	
24		Washer		2	Q235A	
25		Bearing 2512	SF-1	2	Standard	
26		Down pulley	FL-8224-A1-B2	2	Q235A	
27		Slider	FL-8224-A3-B6	16	Nylon	
28		Pulling rod	FL-8224-A3-B2	4	Welded	
29		Pressure spring	FL-8224-A3-B5	4	Zinc-plating	
30		Teeth block	FL-8224-A3-B4	4	Zinc-plating	
31		Elastic cylindrical pin M5*35	GB/T879.1-2000	4	Standard	
32		Circlip 22		4	Standard	
33		Carriage	FL-8224-A3-B1	2	Welded	
34		Protection rubber pad	FL-8224-A3-B7	2	Rubber	
35		Cross socket flat head screwM8*16		4	Standard	
64		Shaft	FL-8224-A12	4	Welded	



Technical changes for purposes of a technical advancement as well as deviation in colour, errors and printing mistakes are reserved.

Annex7, Spare parts list

Spare parts list -for the electrical system

S/N	Material #	Item	Spec.	Qty	Pic	Note
1		Power switch	LW26GS-20/04	1		
2		Button	Y090-11BN	1		
3		Power indicator	AD17-22G-AC24	1		
4		Transformer	JBK3-160VA380V-24V JBK3-160VA220V-24V	1		
5		AC contactor	CJX2-1210/AC24	1		
6		Circuit breaker	DZ47-63 C16/3P DZ47-63 C32/2P	1		
7		Circuit breaker	DZ47-63 C3/1P	1		
9		Limit switch	ME8104	1		
11		Emergency stop	Y090-11ZS/red	1		
12		Bridge rectifier	KBPC5A-35A	1		
13		Capacitor	4700UF/50A	1		
14		Relay	LY2NJ/AC24	1		
15		Relay holder	PTF-08A	1		

Technical changes for purposes of a technical advancement as well as deviation in colour, errors and printing mistakes are reserved.

S/N	Material #	Item	Spec.	Qty	Pic	Note
16		Time relay	ST6PA-5S/AC24V	1		
17		Time relay holder	PYF-08AE	1		
18		Control box	230*380*135	1		

Spare parts list – for the mechanical system

S/N	Material #	Name	Drawing#/Spec.	Qty	Property	Note
1		Slider	FL-8224-A3-B6	16	Nylon 1010	
2		Rubber lifting pad	FL-8224-A7-B3-C4	4	Rubber	
3		O-seal ring	(ID)23.6*3.55	1		
4		Y- seal ring	KD 63*48*10	1		
5		Anti-dust ring	DHS 40*48*5/6.5	1		



Preperation protocol

The lift type with the
serial number: was built on
by the company in
and was checked for safety and function and was put into operation.

The set up and preparation was carried out by the OPERATOR | EXPORT

The safety of the lift was checked by an .

The operator confirms the installation of the lift, and qualified experts have confirmed proper install before launching unit.

Date Owner/ Operator Signature

Date Installation expert Signature

Address Owner/ Operator:

Address Installation expert:



Inspection findings

Regular/ extraordinary inspection

On the date of this lift was put through a regular/ extraordinary and thorough inspection. During this inspection these issues were/ were not found.

.....

Scope of the audit:

Outstanding partial inspection:

The use of this equipment is authorized and the machine and all features have been inspected .

Location/ Date

Inspectors signature

Operator or agent

Taken notes of the defects

Defect corrected
Date Signature

Verification

Date Signature

On the date of this lift was put through re-inspection. During this inspection these issues were/ were not found.

The use of this equipment is authorized and the machine and all features have been inspected.

Location/ Date

Inspectors signature



Safety review pursuant to UVV type

Safety inspection before commissioning/ regular checks/ extraordinary
 (Mark off those that do not apply)

Inspection	Good shape	defective	Re-inspection	Notes
Warning labels/ signs				
Name plate/ ID				
Limit switch function				
Condition of rubber plates				
Function of carrier arm locks				
Supporting structure (cracks etc.)				
Function of safety latches				
All screws tight				
Condition of steel cables				
Condition of covers				
Condition of chain				
Condition of cable pulleys				
Condition of hydraulic lines				
Fluid level of hydraulic unit				
Hydraulic system seals				
Condition of the piston rod				
Condition of electronics				
Function test of the lift				
Foundation condition (cracks)				
Lift Slides/guides in the lift column				
Other				
(Check the appropriate box, if re-inspection is necessary mark that box as well!)				

Inspector (Name, Address):

Inspected on:

Inspection result:

- Commissioning/ use possible. Resolve issues by
- Commissioning/ use prohibited. Re-inspection necessary.
- No defects. Commissioning/ use possible.

Signature owner/ operator:

Signature inspector:



Inspection findings

Regular/ extraordinary inspection

On the date of this lift was put through a regular/ extraordinary and thorough inspection. During this inspection these issues were/ were not found.

Scope of the audit:

Outstanding partial inspection:

The use of this equipment is authorized and the machine and all features have been inspected .

Location/ Date	Inspectors signature
----------------	----------------------

Operator or agent

Taken notes of the defects

Defect corrected
Date Signature

Verification

Date Signature

On the date of this lift was put through re-inspection. During this inspection these issues were/ were not found.

The use of this equipment is authorized and the machine and all features have been inspected.

Location/ Date	Inspectors signature
----------------	----------------------



Safety review pursuant to UVV type

Safety inspection before commissioning/ regular checks/ extraordinary
 (Mark off those that do not apply)

Inspection	Good shape	defective	Re-inspection	Notes
Warning labels/ signs				
Name plate/ ID				
Limit switch function				
Condition of rubber plates				
Function of carrier arm locks				
Supporting structure (cracks etc.)				
Function of safety latches				
All screws tight				
Condition of steel cables				
Condition of covers				
Condition of chain				
Condition of cable pulleys				
Condition of hydraulic lines				
Fluid level of hydraulic unit				
Hydraulic system seals				
Condition of the piston rod				
Condition of electronics				
Function test of the lift				
Foundation condition (cracks)				
Lift Slides/guides in the lift column				
Other				
(Check the appropriate box, if re-inspection is necessary mark that box as well!)				

Inspector (Name, Address):

Inspected on:

Inspection result:

- Commissioning/ use possible. Resolve issues by
- Commissioning/ use prohibited. Re-inspection necessary.
- No defects. Commissioning/ use possible.

Signature owner/ operator:

Signature inspector:



The company

Twin Busch GmbH | Amperestr. 1 | D-64625 Bensheim

declares hereby, that the **2-post vehicle lift**

TW 236 PE + 236 PE B3.9 | 3600 kg

TW 246 PE + 242 PE B3.9 | 4200 kg

serial no.

in the configuration placed on the market by us, meets the relevant safety and health requirements, as required by the following EC directive(s) in it's/their current version(s).

EC-directive(s)

2006/42/EC Maschinen, 2006/95/EC Niederspannung

Applied harmonized standards and regulations

EN 1493:2010 Car lifts

EN 60204-1:2006/A1:2009 Safety of machinery - Electrical equipment of machines

CE Certificate

N8M 15 04 87411 016

M6A 15 04 87411 015

date of issue: 20.04.2015

place of issue: München

technical file no.: 646821 401002

Certification body

TÜV Süd Product Service GmbH,
Ridlerstraße 65,
D-80339 München
Notified Body Appointment No. 0123

Any alteration to the equipment, improper use or installation void this declaration.

Authorized person to compile technical documentation is: Michael Glade (adress as below)



TWIN BUSCH GmbH

Amperestr. 1 · 64625 Bensheim

Tel. 08251 / 70585-0 · Fax: 70585-28

Authorized signatory: Michael Glade
Bensheim, 23.06.15 Qualitätsmanagement

Twin Busch GmbH | Amperestr. 1 | D-64625 Bensheim

twinbusch.de | E-Mail: info@twinbusch.de | Tel.: +49 (0)6251-70585-0



Twin Busch GmbH | Amperestraße 1 | D-64625 Bensheim
Tel.: +49 (0) 6251-70585-0 | Fax: +49 (0) 6251-70585-29 | info@twinbusch.de