



10"-24"

230 V



Please consult our technical decision-maker (on page 52) before purchasing your wheel balancer (s)!

# Wheel balancer

Item No.: TW F-00

## Description

Wheel balancer (semi-automatic).  
Best value for money in professional quality.  
High operating comfort and innovative design are features of our popular model.

## Features

- 1A Quality built with CE-Certificate
- Manufactured in accordance to ISO 9001
- TOP-Design
- Easy handling
- Solid construction
- Digital display
- Automatic measurement with wheel braking
- Static and dynamic balancing
- Several available programs Normal / Static / Alu1, Alu2, Alu3, Motorcycle etc.
- Integrated calibration and self-diagnostic program
- **Optional:** Motorcycle adapter, diverse vehicle adapter

## Delivery contents

- Wheel balancer TW F-00
- Centering cones (4 pcs.) gauge, weight pliers
- Quick release nut, Pressure cup, Rubber lip
- Calibration weight
- English instruction manual | CE-Certificate
- *Product video online | Assembly video*



Product video



Assembly video



## Details



(1) Side holder for centering cones and gauge (2) Integrated distance measurement (3) Quick release nut  $\varnothing = 40$  mm  
(4) 15 storage compartments (5) Digital Display (The new, compartment design ensures maximum user comfort and optimal ergonomics)

## Dimensions | Technical Data | Accessories

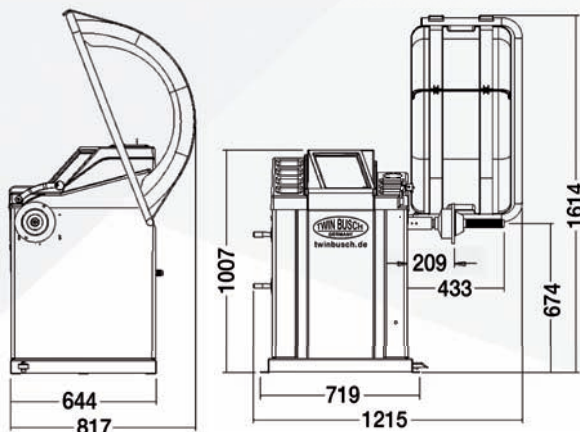

Extensive accessories

### Technical Data: TW F-00

Wheel width	1,5" - 20"
Wheel diameter	10" - 24"
Wheel weight max.	65 kg
Wheel center hole	40-135 mm
Measuring tolerance	+/- 1 g
Measuring time (approx.)	4-7 sec.
Power supply	230 V~
Noise level	< 70 dB
Weight (approx.)	122 kg