

# Tyre changer

Semi-automatic Swing arm design | Item No.: TW X-11



## Description

Robust design tyre changer with side swing mounting arm in professional quality.

## Features

- 1A Quality built with CE-Certificate
- Manufactured in accordance to ISO 9001
- Side swing mounting arm design
- Eccentric tension of mount and demount head
- Powerful bead breaker
- Self centered 4 clamping jaws system
- 24" large turntable for cars and vans
- Tubeless tyre inflating system
- Powerful E-Motor for supply and return lines
- Clamping jaws made of special steel
- Plastic protectors for mounting head / jaws
- Top quality and massive construction

## Delivery contents

- Tyre changer with a maintenance unit
- Inflating gun and bead lever
- Bead press and edge protection
- Clamp protector for clamping jaws system (4 items)
- 3 set plastic protector for mount and demount head (for protection of alloy wheel rims)
- CE-Certificate
- *Product video online*
- *Assembly video*



- ⊕ 12"-24"
- ⊕ 10"-21"
- ⚡ 230 V
- or\*
- ⚡ 400 V
- Both versions available



Product video



Assembly video



Check our technical decisions helper (on page 44) before you buy your Tyre fitting machine

## Details

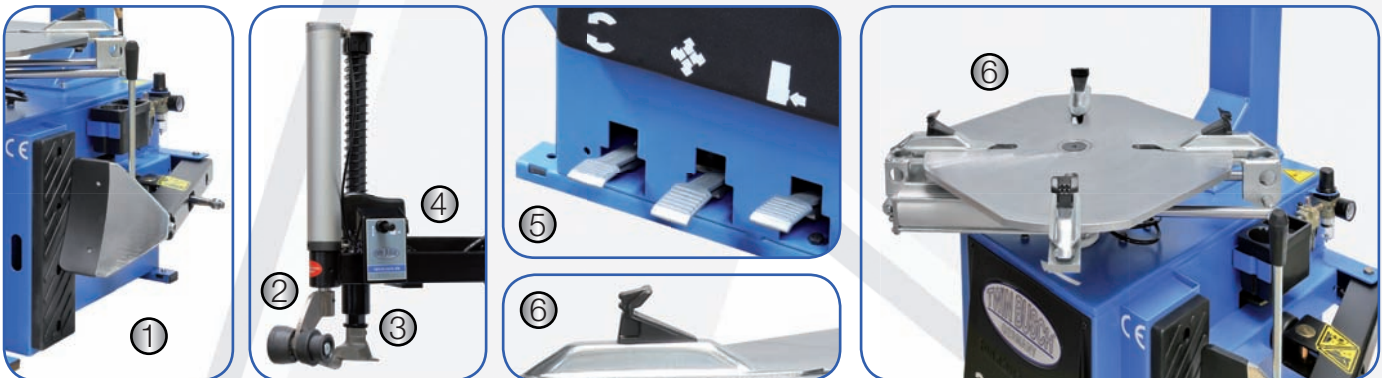

(1) Strong tyre press (2) Help-arm for professional use (3) Mounting head (4) Joystick for fine adjustment (5) Foot pedals (6) Special steel clamps | Large clamping diameter 10" - 24"

## Dimensions | Technical data | Accessories

\*Please note: The products are being sold as the 400-volt model, if desired, please specify the 230-volt version.

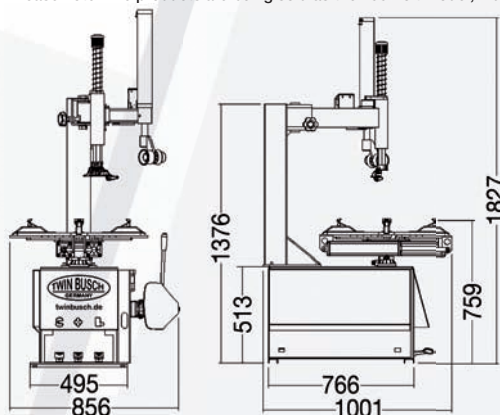

Extensive accessories

Technical Data: TW X-11	
Outside clamping range	10" - 21"
Inside clamping range	12" - 24"
Wheel diameter (max.)	41" (1040 mm)
Wheel width (max.)	14" (355 mm)
Bead breaker force	2500 kg
Air supply	8-10 bar
Power supply	400 V or 230 V*
Motor power	0,75 / 1,1 kW
Noise level	<70 dB
Weight (approx.)	211 kg