



400 V



# Tyre changer

Item No.: TW X-93

## Description

**Top tyre changer with a new type of clamping system**, optimal for sensitive aluminium rims. The wheel is mounted on a spindle using a centering cone (incl. 4 pcs.) and a quick-locking clamp in connection with a bayonet lock.

## Features

- 1A Quality built with CE-Certificate
- Manufactured in accordance to ISO 9001
- Self centering wheel mounting system
- Mounting shaft with quick release system
- 1 Help-arm for professional use
- Wheel lifter
- Mounting head can be moved to the side
- Pneumatic mounting head adjustment
- Large clamping range for cars and vans
- High quality stainless steel components in the inner part
- Precise control block with STOP function
- Powerful bead breaker (2500 kg)
- Powerful electrical motor

## Delivery contents

- Tyre changer with maintenance unit
- Air filler and lifting lever
- Bead press and edge protection
- Plastic protectors for aluminium rims (3 pcs.)
- *Product video online*
- *Assembly video*

**NEW**



**Bead press and edge protection included free of charge!**

Check our technical decisions helper (on page 44) before you buy your Tyre fitting machine

optionally available:

Roll board (can be used on all of our tyre changers)

TW X-ROLL



TW X-93AD

Hole adapter (can also be used on all of our tyre balancers)



Second help-arm (see TW X-98)



Product video



Assembly video



## Details

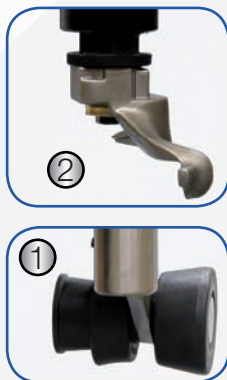

(1) Help-arm for professional use (2) Mounting head (3) Comfortable and clear tire inflator (4) Self centering wheel mounting system (5) Wheel lifter

## Dimensions | Technical data | Accessories

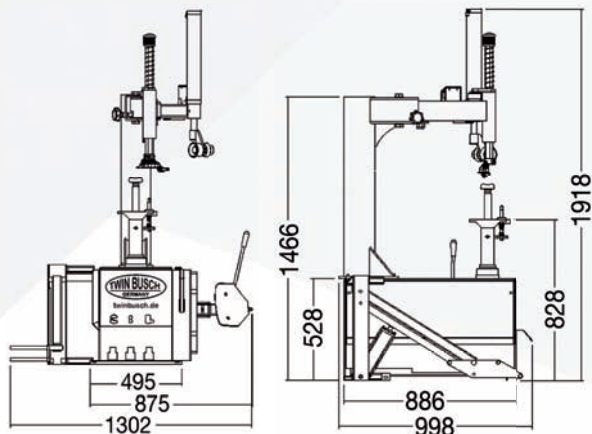

Extensive accessories

Technical Data: TW X-93	
Wheel diameter (max.)	45" (1143 mm)
Wheel width (max.)	16" (406 mm)
Bead breaker force	2500 kg
Air supply	8 - 10 bar
Power supply	400 V
Motor power	0,75 kW
Noise level	<70 dB
Weight (approx.)	269 kg