



12" - 22"

10" - 19"

230 V

**NEW**



**Bead press and edge protection included free of charge!**

**TW X-610 + TW F-100 also available as a set!**



Hand operated Wheel balancer TW F-100

Perfect accessory to the TW X-610. Detailed information on page 51.



# Basic-Line Tyre changer

Semi-automatic Swing arm design | Item No.: TW X-610

## Description

Tyre changing machine with swing arm design, the ideal starter model with TOP price - performance ratio, user friendly and an innovative design.

## Features

- 1A Quality built with CE-Certificate
- Manufactured in accordance to ISO 9001
- Side swing mounting arm design
- Eccentric tension of mount and demount head
- Powerful bead breaker
- Self centered 4 clamping jaws system
- 22" large turntable for cars and vans
- Tubeless tyre inflating system
- Powerful E-Motor for supply and return lines
- Clamping jaws made of special steel

## Delivery contents

- Tyre changer with a maintenance unit
- Inflating gun and bead lever
- Bead press and edge protection
- 3 set plastic protector for mount and demount head (for protection of alloy wheel rims)
- CE-Certificate
- Product video online
- Assembly video



Product video



Assembly video



Check our technical desicions helper (on page 44) before you buy your Tyre fitting machine

## Details



(1) Strong tyre press (2) Eccentric clamping (3) Mounting head (4) Comfortable foot pedal (5) Wide clamping range

## Dimensions | Technical data | Accessories

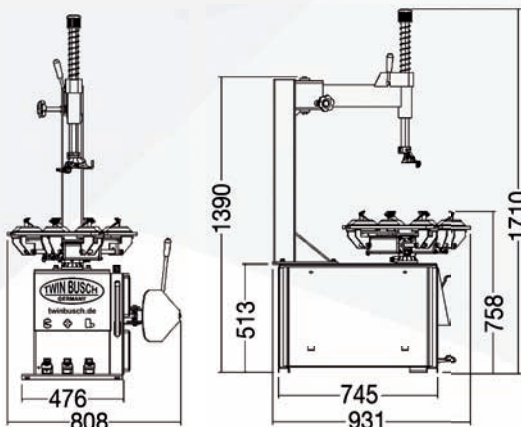

Extensive accessories

Technical Data: TW X-610	
Outside clamping range	10" - 19"
Inside clamping range	12" - 22"
Wheel diameter (max.)	41" (1040 mm)
Wheel width (max.)	14" (355 mm)
Bead breaker force	2500 kg
Air supply	8-10 bar
Power supply	230 V
Motor power	1,1 kW
Noise level	<75 dB
Weight (approx.)	188 kg