



F 536S GT RACING MI

CORMACH
CORREGGIO MACHINERY

IT Smontagomme automatico per autovetture e veicoli commerciali leggeri.
Opera su pneumatici Low Profile e Run Flat e su cerchi sportivi in alluminio.

EN Automatic tyre changer for cars and light commercial vehicles,
suitable for Low Profile and Run Flat tyre as well as for sport alloy rims.

FR Démonte pneus automatique pour voitures et camionnettes,
qui permet de travailler sur pneus Run Flat et surbaissés et sur des roues de sport à jantes larges.

DE Automatische Reifenmontiermaschine für PKW und leichte Nutzfahrzeuge mit Low-Profile und Run-Flat-Reifen.

DK Automatisk dækapparat til biler og lette varevogne med lavprofil og Run Flat dæk.

**LIGHT
now!**



IT Disponibile nella
versione con dispositivo
Light Now! (a richiesta)

EN Available with Light
Now! device (on request)

FR Avec dispositif Light
Now! (sur demande)

DE Mit Light Now!
Vorrichtung (Auf Anfrage)

DK Tilgængelig med Light
Now lys (anfordres).



26"

IT Bloccaggio cerchi da 12" a 26".

EN Rim capacity from 12" to 26".

FR Blocage jantes de 12" à 26".

DE Felgenreterierung von 12" bis 26".

DK Fælg kapacitet fra 12" til 26".



IT Comando pneumatico salita/discesa del braccio operante.

EN Pneumatic control for up/down operating mounting head.

FR Commande pneumatique de montée/descente du bras porte outil.

DE Pneumatiksteuerung zum Heben/Senken des Betriebsarms.

DK Pneumatisk kontrol for op og ned styring af monteringshovede.

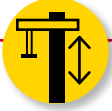

IT Grazie a un sistema pneumatico di sollevamento del braccio operante, che viene azionato tramite una valvola, il palo può essere sollevato sino a permettere di operare su ruote di 15" di larghezza.

EN Thanks to a pneumatic system which raises the arm, the column can be lifted higher enabling this way to operate on wheels of 15" width.

FR Grâce au système pneumatique d'élevation qui s'actionne par une soupape, la colonne peut être soulevée jusqu'à permettre d'opérer sur des roues d'une largeur de 15".

DE Dank eine Druckluftanlage, funktionierten mittels eines Ventils, kann der Arm in eine arbeitsgerechte Position zur Demontage von Reifen mit einer Breite von 15" angehoben werden.

DK Takket være et pneumatisk system som hæver armen kan søjlen løftes højere, og derved gøre det muligt at arbejde med fælg med en bredde op til 15".



IT Palo ribaltabile pneumaticamente con comando a pedale.

EN Pneumatic tilting column by pedal control.

FR Basculement du bras avec commande pneumatique à pédale.

DE Über Fußsteuerung pneumatisch neigbarer Ständer.

DK Pneumatisk søjlestyring styres med fodpedal.



IT Velocità di rotazione variabile (motoinverter), comando a pedale.

EN Variable rotation speed (motoinverter) by pedal control.

FR Vitesse de rotation variable (motoinverter) avec commande a pédalé.

DE Variable Rotationsgeschwindigkeit (Geschwindigkeitsinverter), Fußsteuerung.

DK Variabel rotationshastighed (motorinverter) med pedal kontrol.



IT Dotato di dispositivo per il gonfiaggio di pneumatici tubeless. Include un serbatoio aria e un manometro per il gonfiaggio rapido dei pneumatici.

EN Equipped with the special built-in device for tubeless inflation. Provided with an air tank and a manometer for the faster tyre inflation.

FR Avec gonfleur pour pneus tubeless. Un réservoir d'air et un manometre pour le gonflage rapide des pneus.

DE Ausstattung mit einer Vorrichtung zur Befüllung von Tubeless-Reifen. Es umfasst einen Lufttank und ein Manometer zur schnellen Aufblasen der Reifen.

DK Udstyret med denne specielle indbyggede enhed til slangeløs oppustning. Udstyret med en lufttank og et manometer til hurtigere dækinflation..

F 536S GT
RACING
LIGHT now!

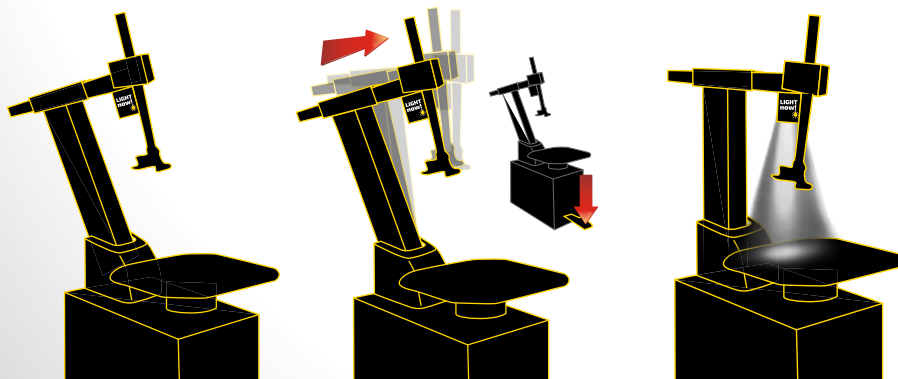



IT La paletta dello stallonatore prevede due diverse inclinazioni per facilitare le operazioni di stallonatura su ruote di tutti i diametri.

EN The bead breaker offers two different positions in order to facilitate the bead-breaking operations on wheels of all diameters.

FR La palette décolleur permet deux inclinaisons différentes pour faciliter les opérations de décollage sur les roues de tous les diamètres.

DE Die Wulstabdrückvorrichtung hat zwei verschiedene Neigungen, um die Reifenabdrückung auf Rädern aller Durchmesser zu erleichtern.

DK Dækpresseren har to forskellige indstillinger for at lette dækbrud på hjul i alle diameter.

IT Cilindro stallonatore a doppio effetto.

EN Double acting bead breaker cylinder.

FR Vérin décolleur à double effet.

DE Doppelt wirkender Abdrückzylinder.

DK Dobbeltvirkende dækpressecylinder.



IT Sistema di recupero giochi.

EN Clearance regulation systems equipped with conic bushes for an easy maintenance.

FR Système de récupération des jeux.

DE Spielwiederherstellungssystem.

DK Clearance reguleringsystemer udstyret med koniske bøsninger for nem vedligeholdelse.

Dotazione Standard • Standard tilbehør

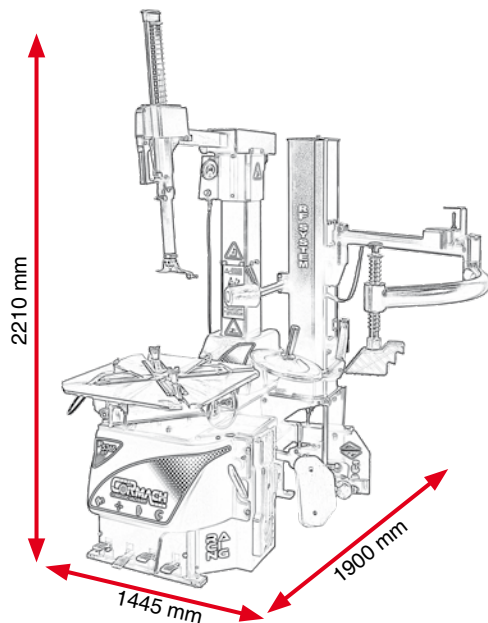

Accessori Opzionali • Valgfri tilbehør



Dati tecnici • Technical data • Données techniques • Technisches Daten • Tekniske data

• Diametro massimo ruota • Max wheel diameter	• Larghezza massima ruota • Max wheel width	• Bloccaggio esterno • Outside locking capacity	• Bloccaggio interno • Inside locking capacity	• Pressione di esercizio • Working pressure	• Alimentazione • Power supply	• Forza stallonatore • Bead breaker power	• Apertura max stallonatore • Bead breaker max opening	• Velocità di rotazione • Rotation speed	• Peso netto • Net weight
• Diamètre maximal de la roue • Max. Radaussendurchmesser • Diámetro máx de la rueda	• Largeur maximal de la roue • Max. Reifenbreite • Ancho máx de la rueda	• Blocage extérieur • Aussenseitige Aufspannen • Para ruedas de exterior	• Blocage intérieur • Innerseitige Aufspannen • Para ruedas de interior	• Pression de travail • Betriebsdruck • Presión de trabajo	• Alimentation • Stromversorgung • Alimentación	• Force décolleur • Abdrückerkraft • Fuerza destalonador	• Ouverture maxi décolleur • Max Öffnung Abdrückschaufel • Apertura máx destalonador	• Vitesse de rotation • Dreh-Geschwindigkeit • Velocidad de rotación	• Poids net • Nettogewicht • Peso neto
1100 mm (43")	400 mm (15")	12" - 24"	15" - 26"	8 - 10 bar	230V 50-60 Hz 1ph	3000 Kg	390 mm	6 - 12 rpm	318 Kg